

# English for Syria

Elementary  
Activity Book

R. T. Nasr  
D. Dallas

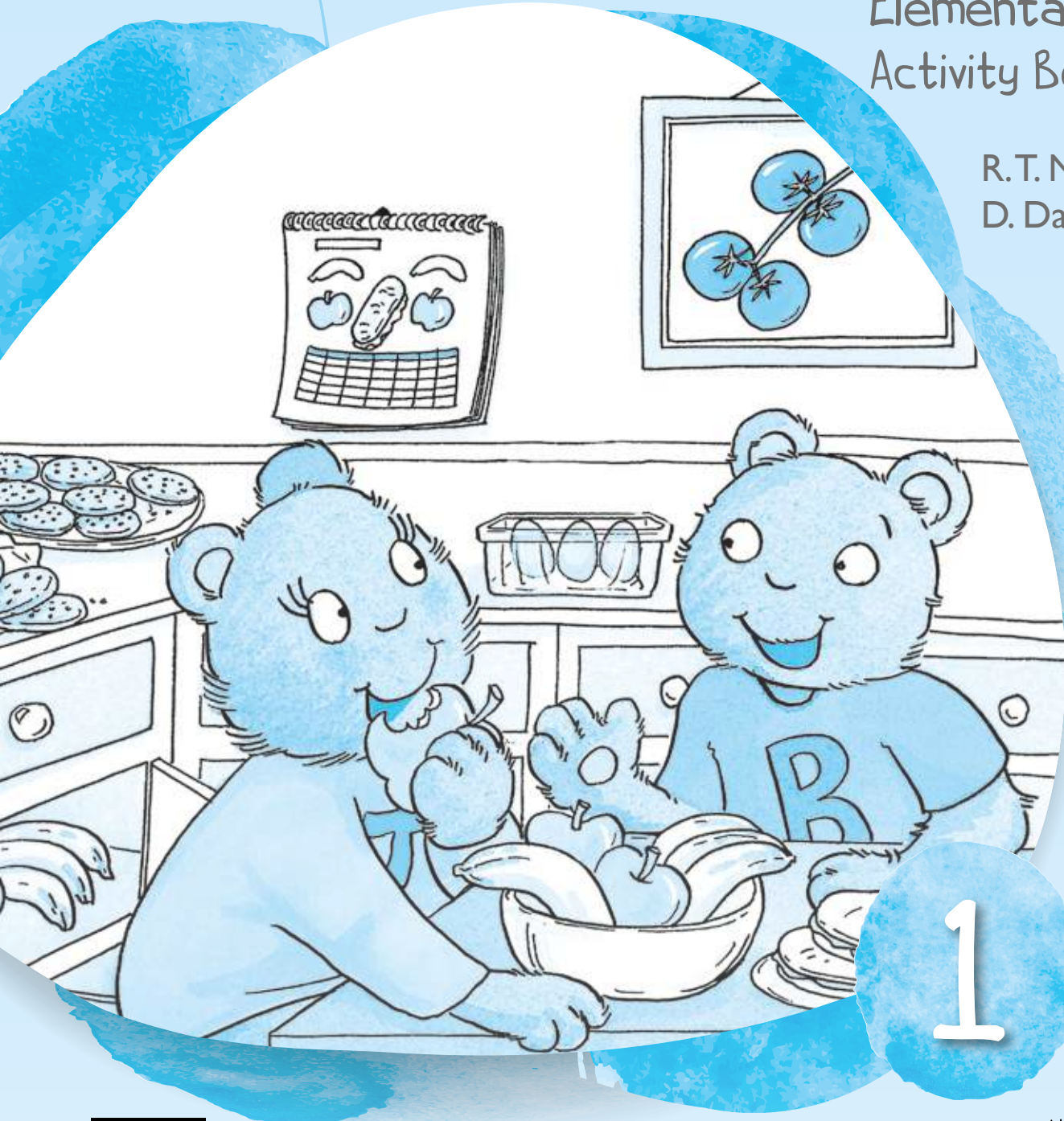

1

اعتمد من قبل المركز الوطني لتطوير المناهج التربوية  
حقوق التوزيع في الجمهورية العربية السورية  
محافظة للمؤسسة العامة للطباعة

تدقيق ومواءمة كتب اللغة الإنكليزية  
باسل صادق  
رشا بايزيد  
سرور شلش  
شهرزاد الفراتي  
عبد الماجد أوغرلي  
علا داود آغا  
لينا الذياب

وردت الأسماء حسب الترتيب الهجائي.



322 Old Brompton Road,  
London SW5 9JH,  
England

**Maktabat El Nashr El Tarbawi El Souri**  
(Syrian Educational Publishers)

Omar El Mukhtar 2nd Str., Bldg. 6  
El Mazraa, Damascus-Syria  
Phone: (011) 44676789  
Fax: (011) 44676788  
e-mail: info@syrianep.com  
www.syrianep.com

First edition published 2002  
Second edition 2007  
Third edition 2018

© York Press 2002

*All rights reserved; no part of this publication  
may be reproduced, stored in a retrieval system,  
or transmitted in any form or by any means, electronic,  
mechanical, photocopying, recording or otherwise,  
without the prior written permission of the Publishers.*

© جميع الحقوق محفوظة: لا يجوز نشر أي جزء من هذا الكتاب أو تصويره أو تخزينه أو تسجيله بأي وسيلة دون موافقة خطية من الناشر.

# Contents

Unit		Page
Unit 1	Hello! .....	5
Unit 2	Counting .....	8
Unit 3	Classroom objects .....	11
Unit 4	Close the window, please. ....	14
Unit 5	Revision 1 .....	17
Unit 6	Let's eat! .....	20
Unit 7	What colour is the ...? .....	23
Unit 8	My face .....	26
Unit 9	My family .....	29
Unit 10	Revision 2 .....	32
Unit 11	My birthday .....	35
Unit 12	Is the bed green? .....	38
Unit 13	My body .....	41
Unit 14	What's that? .....	44
Unit 15	Revision 3 .....	47

<b>Unit</b>	<b>Page</b>
Unit 16 Our clothes .....	50
Unit 17 Where is it? .....	53
Unit 18 I like ice cream.....	56
Unit 19 Animals .....	59
Unit 20 Revision 4 .....	62
Unit 21 Is that Zeina's vase? .....	65
Unit 22 Where's Mother? .....	68
Unit 23 I'm tall.....	71
Unit 24 The alphabet .....	74
Unit 25 Revision 5 .....	77
Handwriting Practice .....	83



# I Hello!

1 Trace the lines.

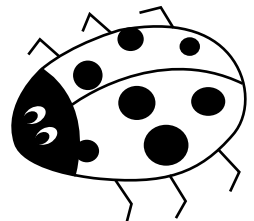
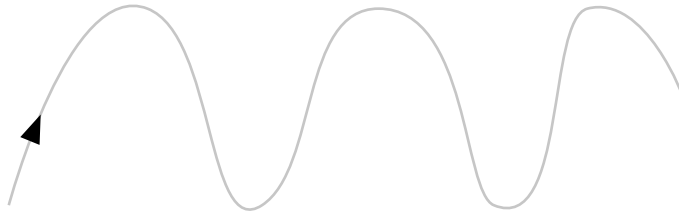
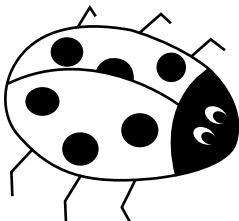
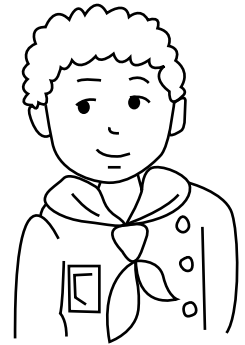
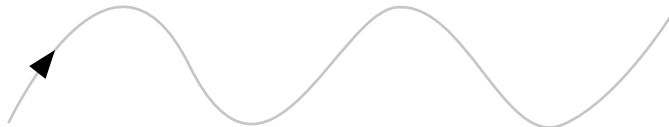
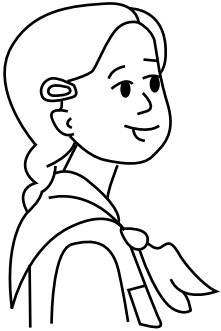
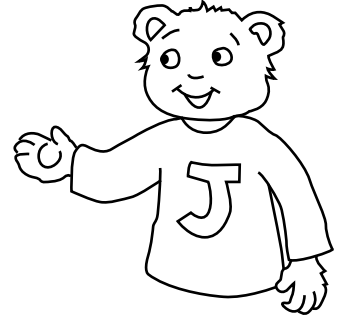
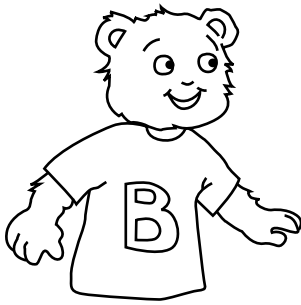

2 Trace a line for Miss Reem to get to the board.

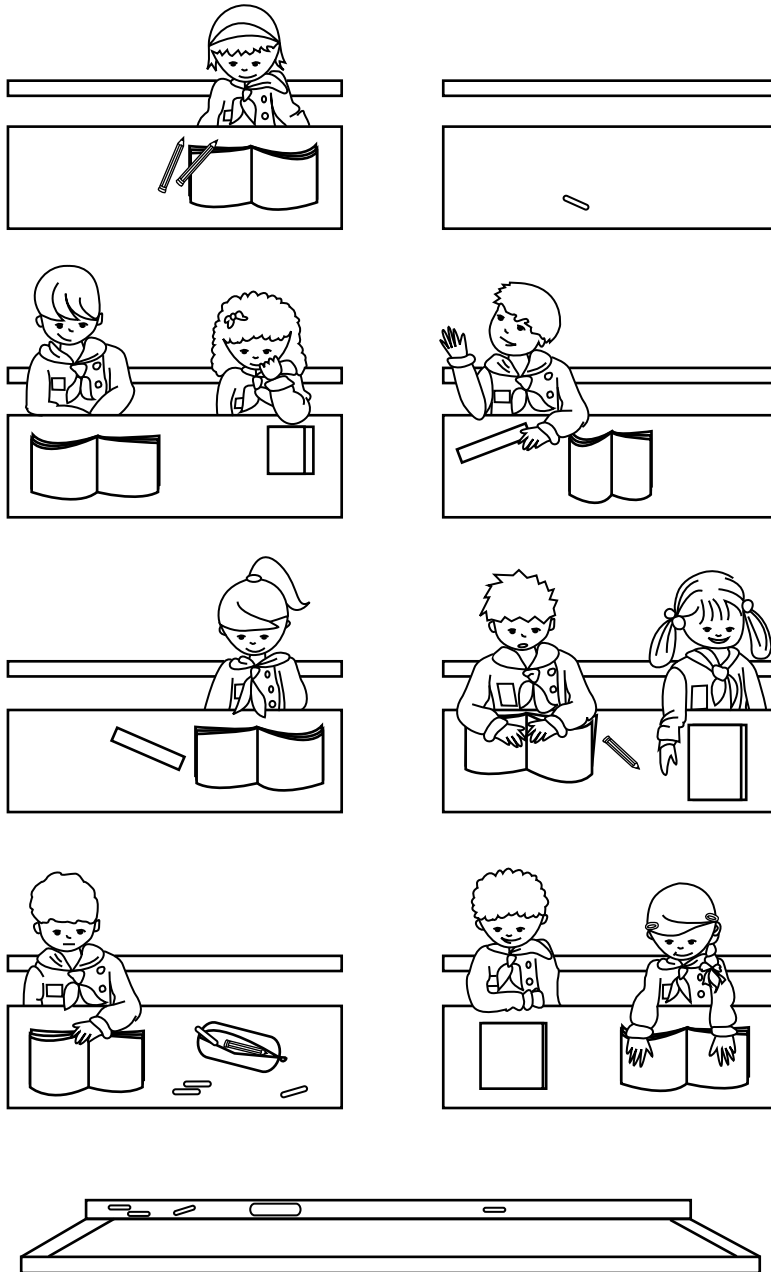

3  Listen to the three conversations. Repeat them and match the pictures.

1

Hello!



a

I'm Eman.



2

What's your name?



b

Hello!



3

How are you?



c

I'm fine, thank you.



# 2 Counting

1 Trace the lines.

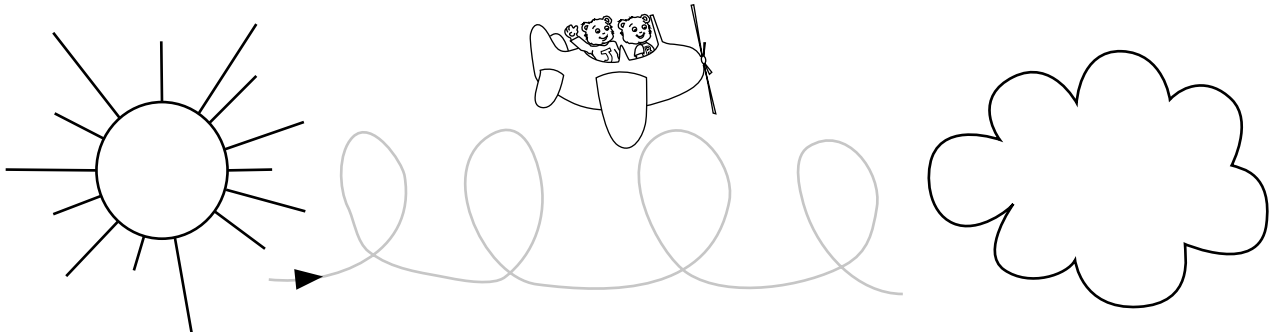
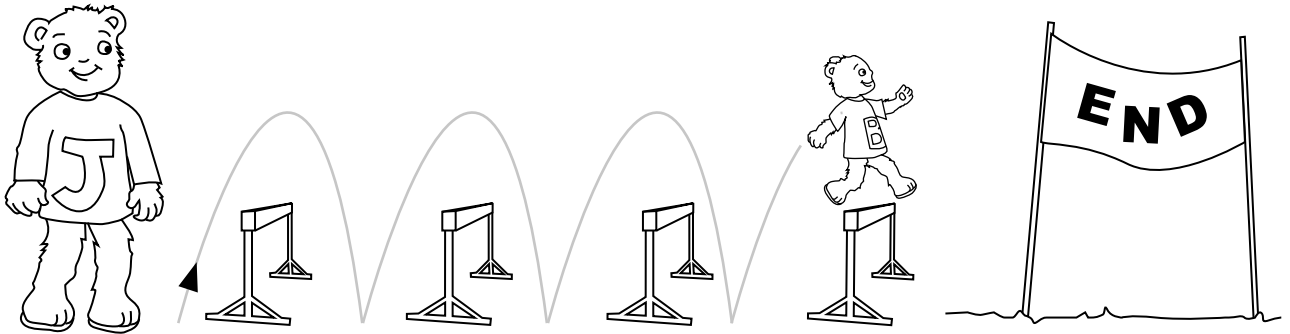
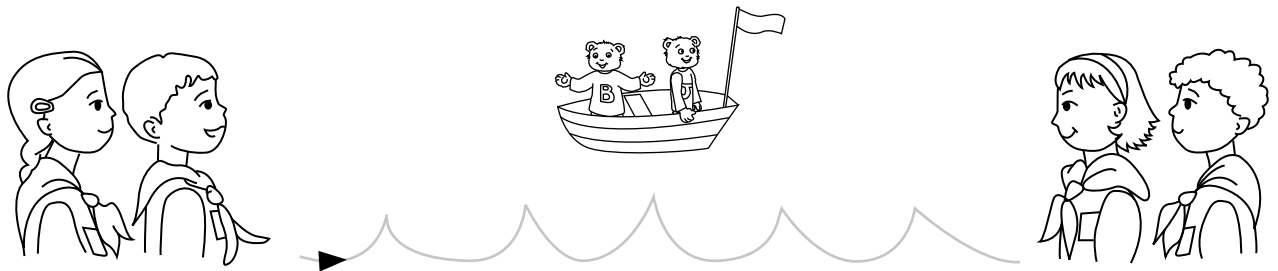
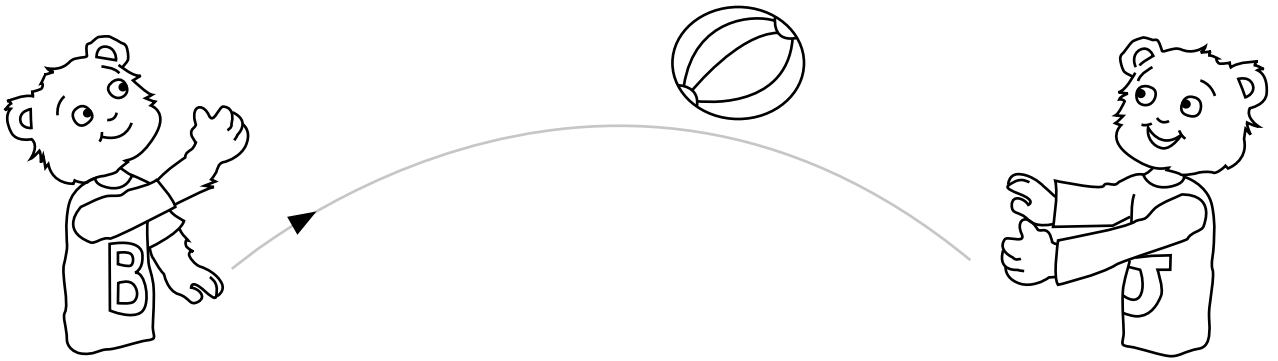

2  Listen to the numbers and repeat them. Then, trace them.

1

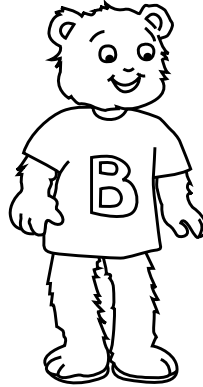
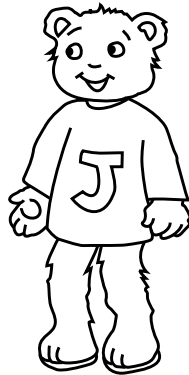

2

3

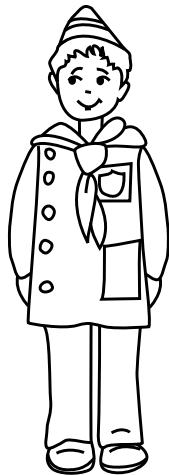

4

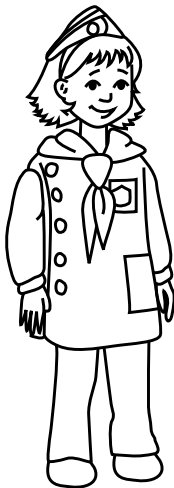

5



3 Trace and copy the numbers.

1 1 1

2 2 2

3 3 3

4 4 4

5 5 5



# 3

## Classroom objects

1 Trace the letter. Then, copy it five times.

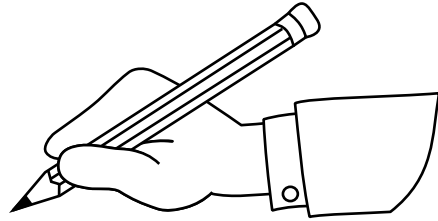
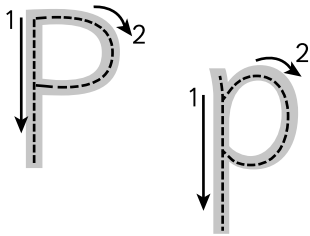

pencil

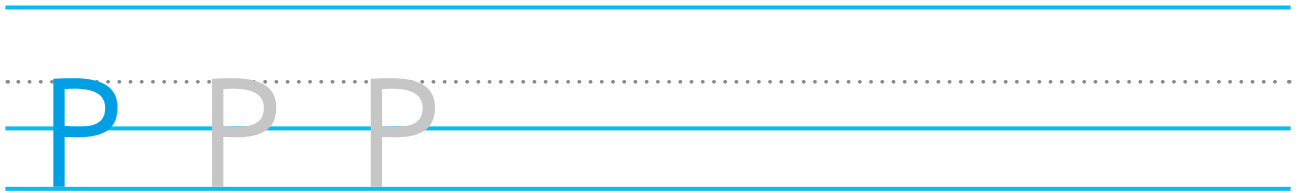

2 Find and circle the letter p.

p

pencil

stand up

computer

3  Listen to the conversations and trace the lines.

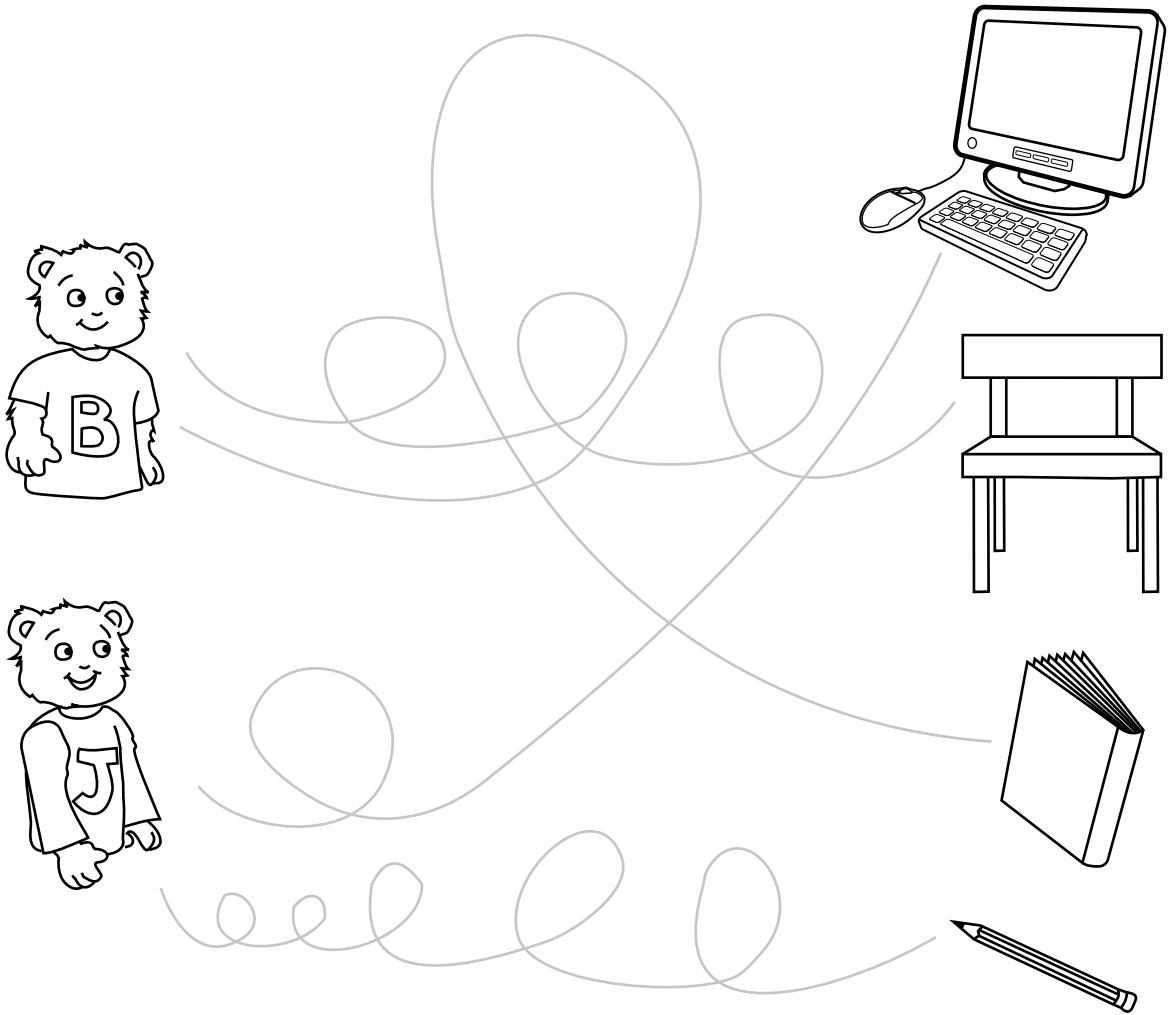

4 Look at the pictures. Ask and answer questions about the objects.

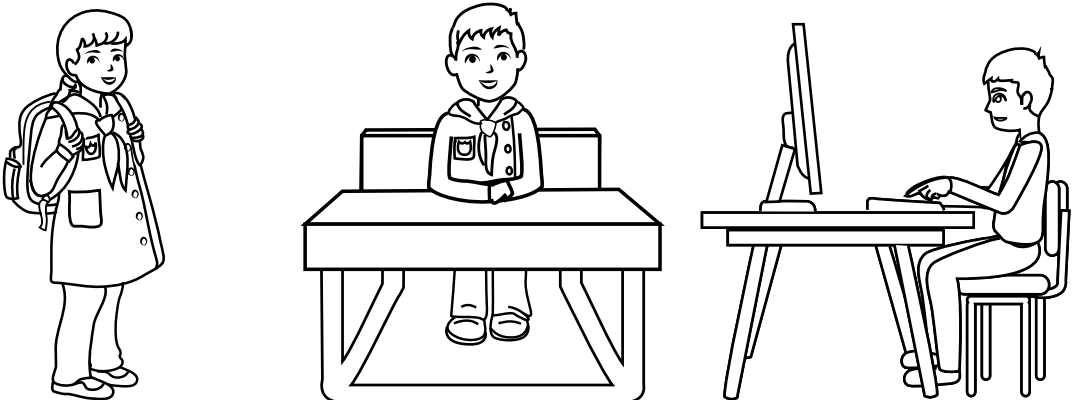

5 Find and circle the numbers.

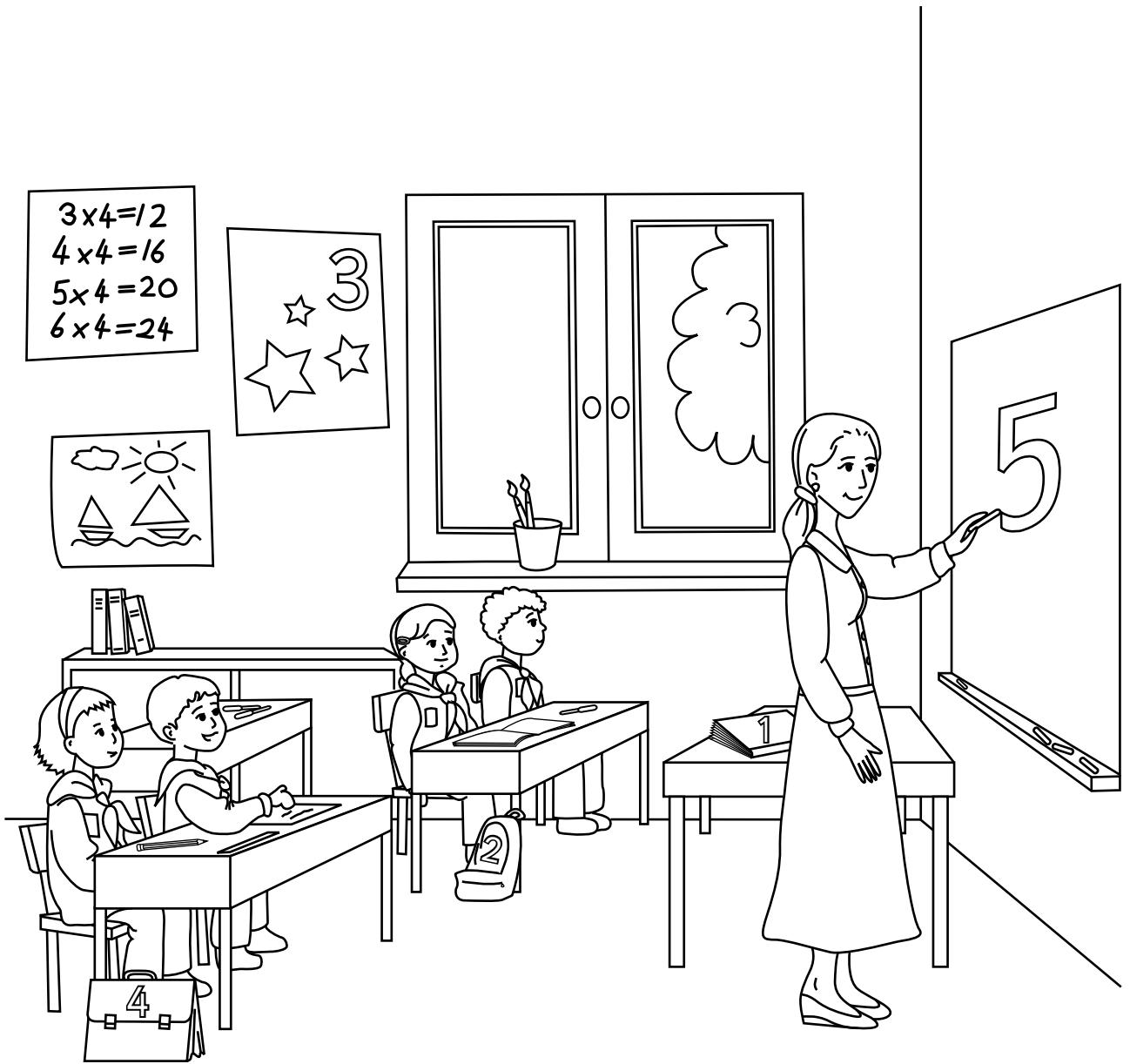

# 4

## Close the window, please.

1 Trace the letter. Then, copy it five times.

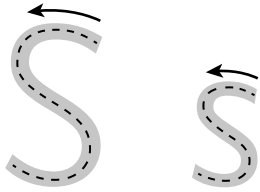

stand up



S S S

S S S

2 Complete these words with one letter.

\_\_it down

\_\_tand up

de\_\_k

3 Circle the girls and cross out the boys.



4 Count the girls and count the boys. Write the numbers.

girls

boys

5  Draw a line for Salma to find Zeina. On her way, listen to the questions and answer them.

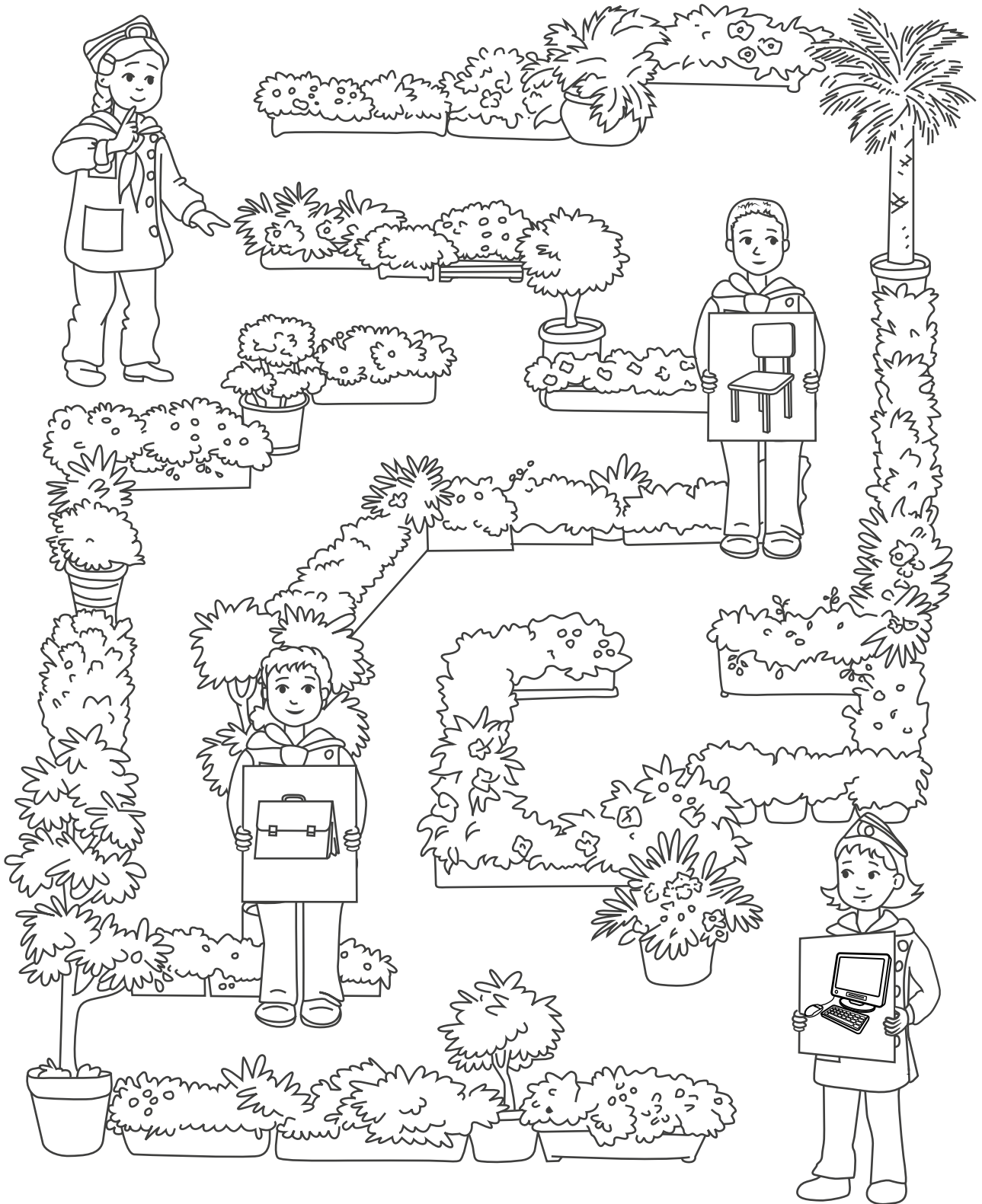



# 5 Revision 1

1 Trace the letters. Then, match the words with the pictures.

open



sit down

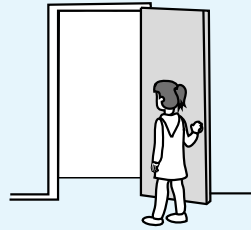

pencil



desk



stand up

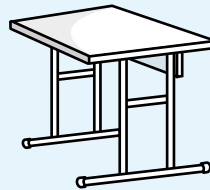

computer



please



2  Listen to the conversations and circle the correct answer.

1

a

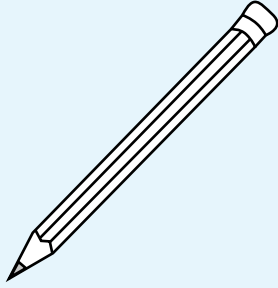

b

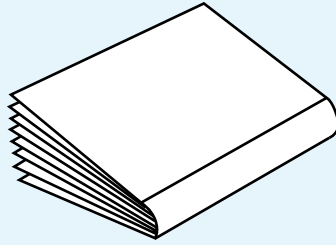

c

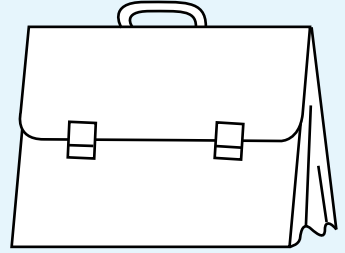

2

a

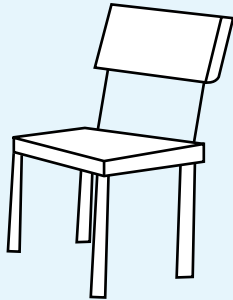

b

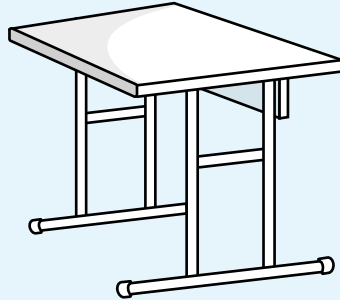

c

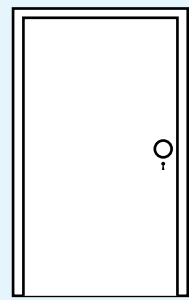

3

a

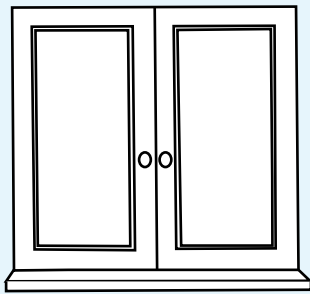

b

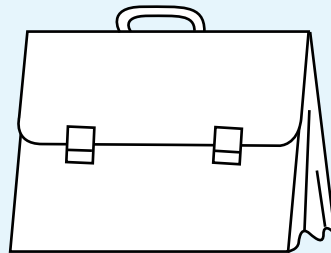

c



4

a

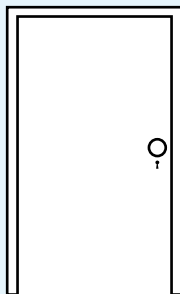

b

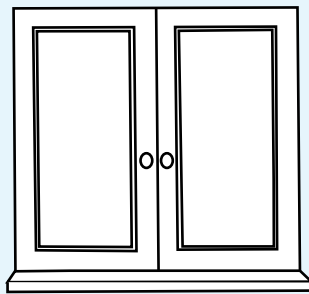

c

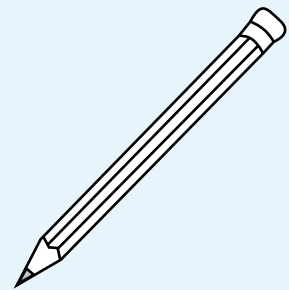

3 Count the objects and circle the correct number.

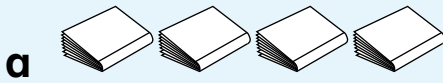

1 2 3 4 5



1 2 3 4 5

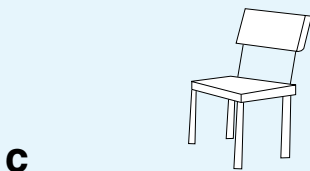

1 2 3 4 5

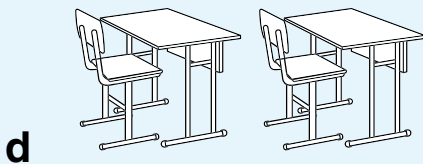

1 2 3 4 5

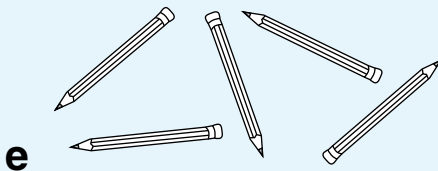

1 2 3 4 5

4 Draw lines to complete the picture. What's this? Tell the class.

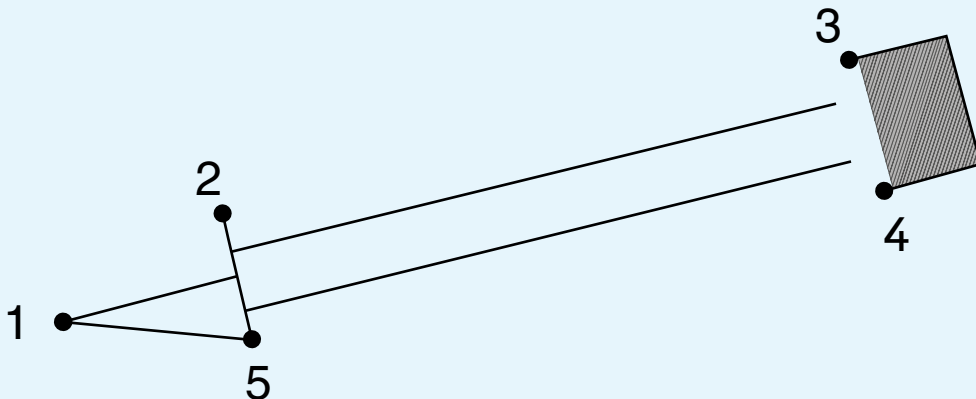

# 6

## Let's eat!

1 Trace the letter. Then, copy it five times.

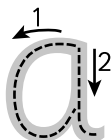
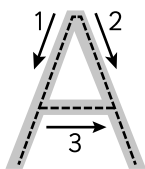

apple

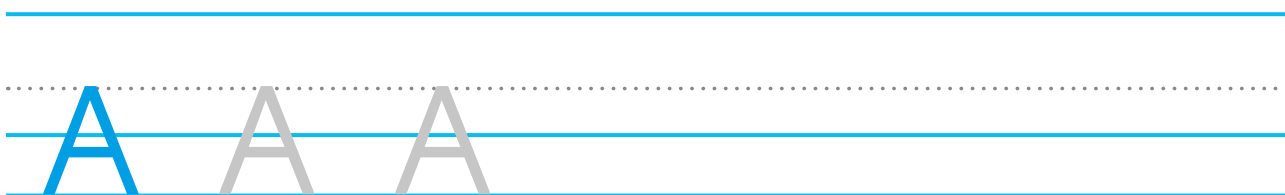
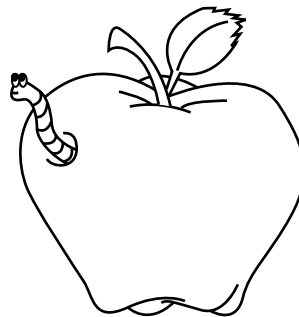

2 Find and circle the letter a. Then, match the words with the pictures.

bag

apple

sandwich

banana

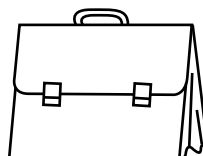

3 Trace the picture.

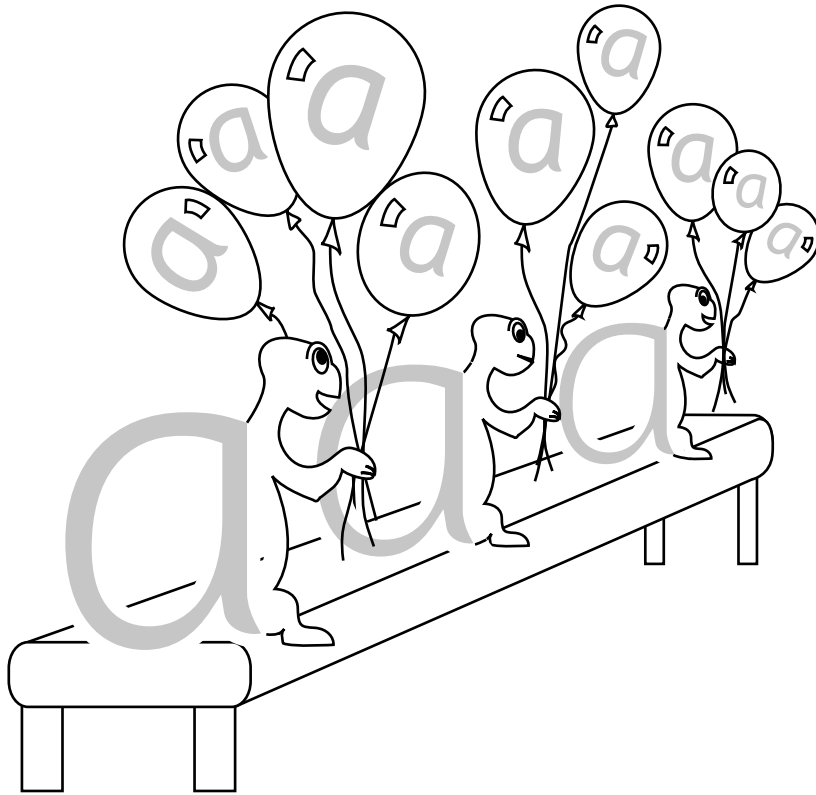

4 Look at the pictures. Circle the correct answer.

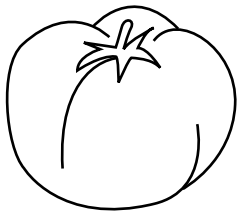

Is this **an apple** /  
**a tomato**?

Yes, it is.

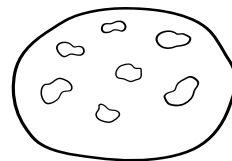

Is this a sandwich?

No, it isn't. It's

**a biscuit** / **a sandwich**.

- 5  Listen to the conversations and tick (✓) the correct answer. Then, draw the food.

1  a No, it isn't.  
It's a tomato.

2  a Yes, it is a  
sandwich.

b No, it isn't.  
It's a banana.

b Yes, it is.

- 6 Work in groups. Draw an object or a food. Your group guesses what it is. Take turns, asking and answering questions about the items.



# 7

## What colour is the ...?

1 Trace the letter. Then, copy it five times.

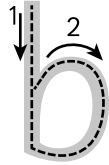
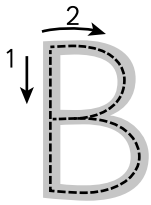

bus

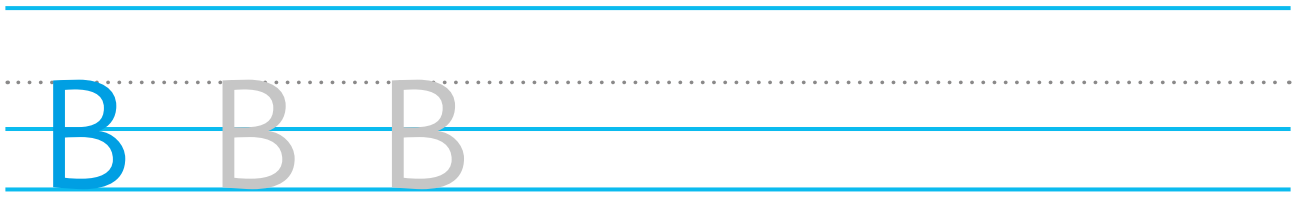
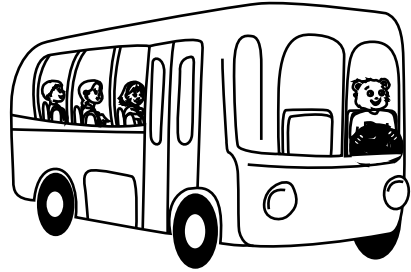

2 Circle the pictures that have their name beginning with the letter **b**.

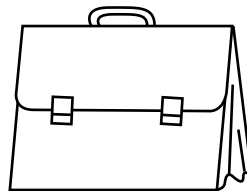
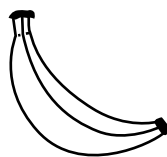
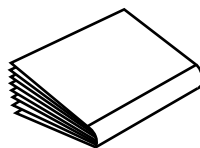
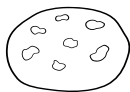

3 Trace the picture.



4 Trace the pictures and colour them.

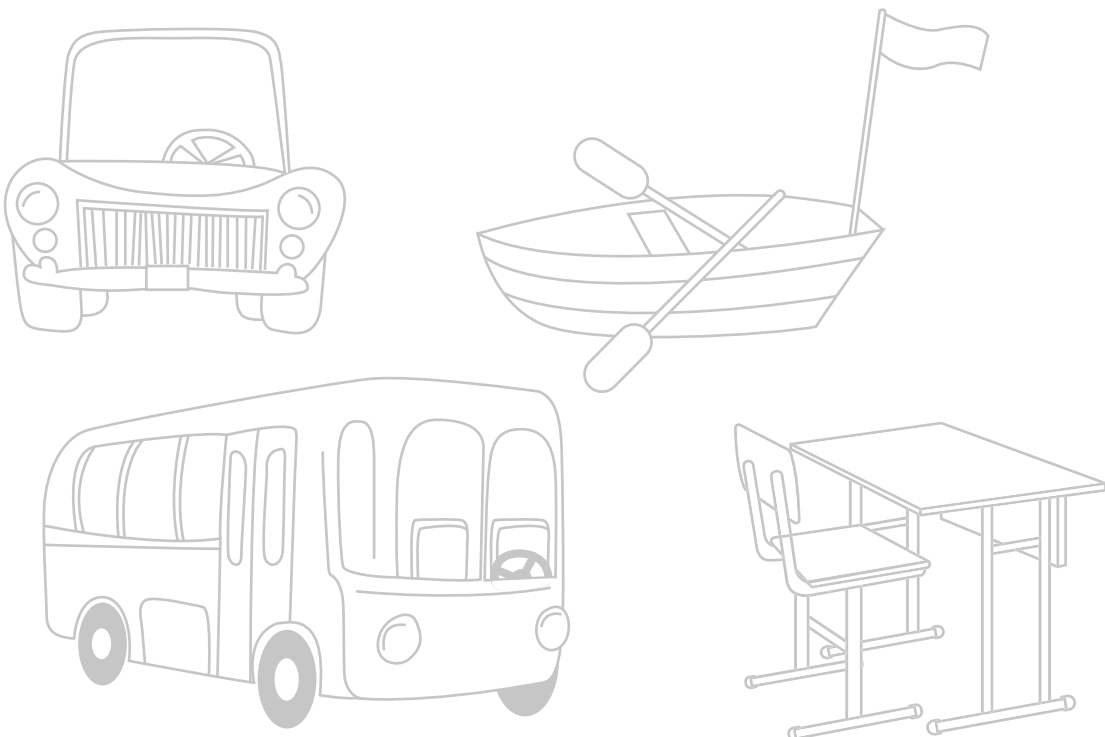

5  Listen and colour.

1



2

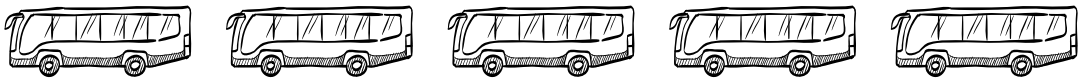

3



4



6 Work in pairs. Ask your partner about the colours of the objects in Exercise 5. Then, ask him or her to colour the rest, choosing the colour that you want.



What colour is the house?

The house is red.

Colour this house blue.



# 8 My face

1 Trace the letter. Then, copy it four times.

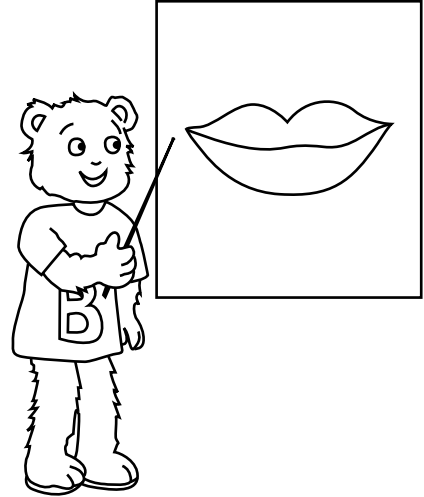
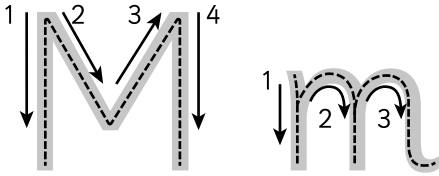

mouth



2 Find and circle the letter m.

m mouth name many my tomato

3 Trace the picture.

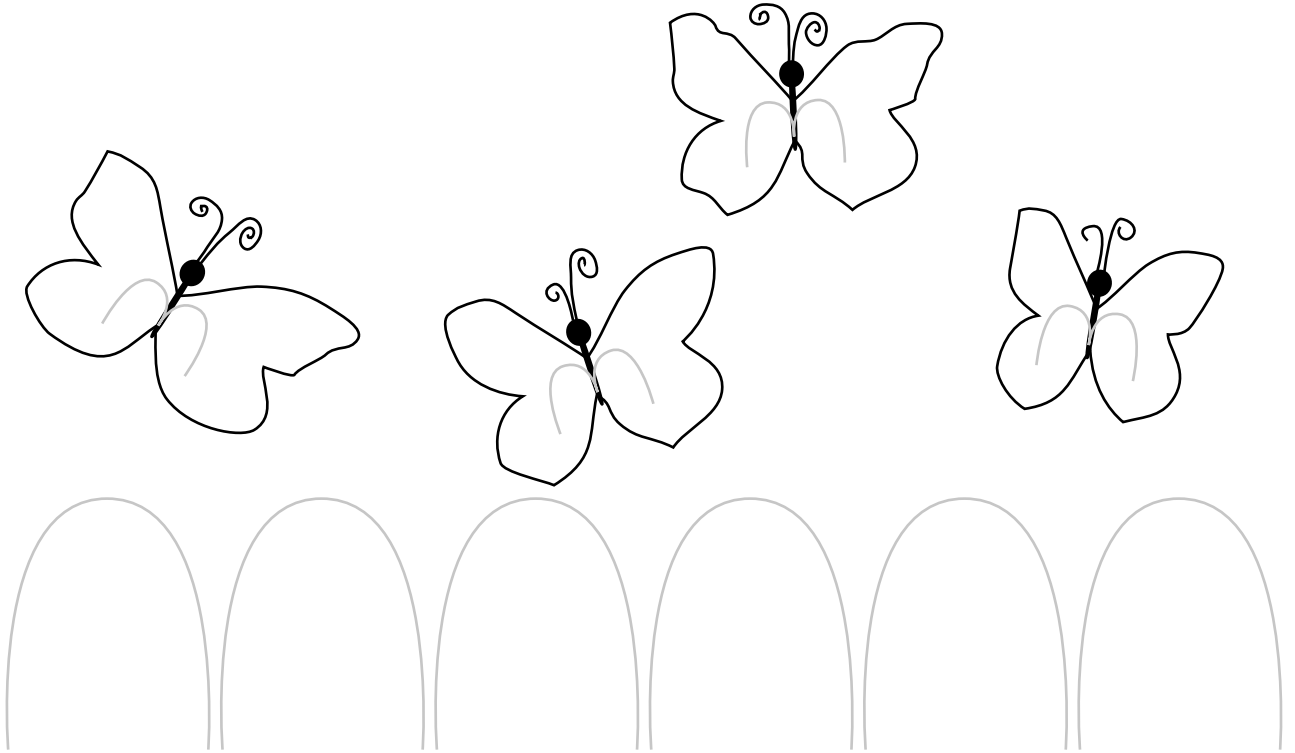

4 Draw your face. Then work in pairs, point to the parts of your face and tell your partner what they are: *This is my mouth ...*



- 5  Listen, trace the words and match them to the parts of the face in the picture.



- 6 Work in pairs. One pupil reads the question and the other looks at the picture and answers.

Is this your eye?



Is this your nose?



Is this your mouth?



Is this your ear?





# 9

# My family

1 Trace the letter. Then, copy it five times.

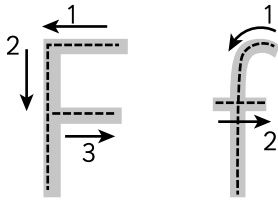

father



2 Find and circle the letter f.

**f** father face family four fine finger

3 Trace the picture.

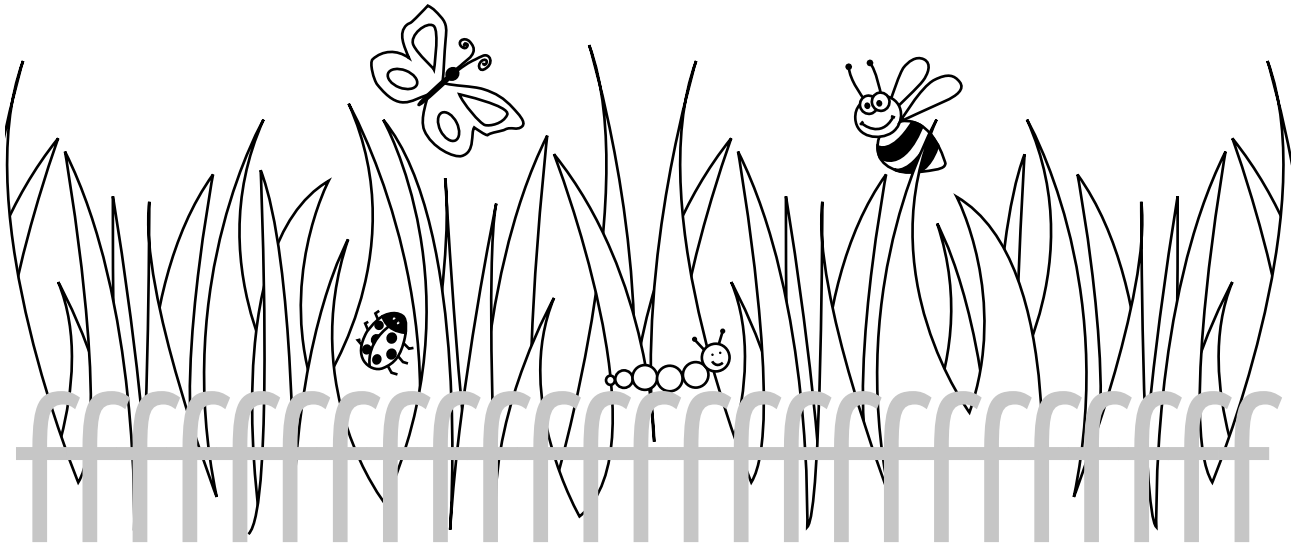

4 Read the sentences. Then, draw the pictures and match them to the correct sentences.

This is my mother.

This is my brother.

This is my father.

This is my sister.

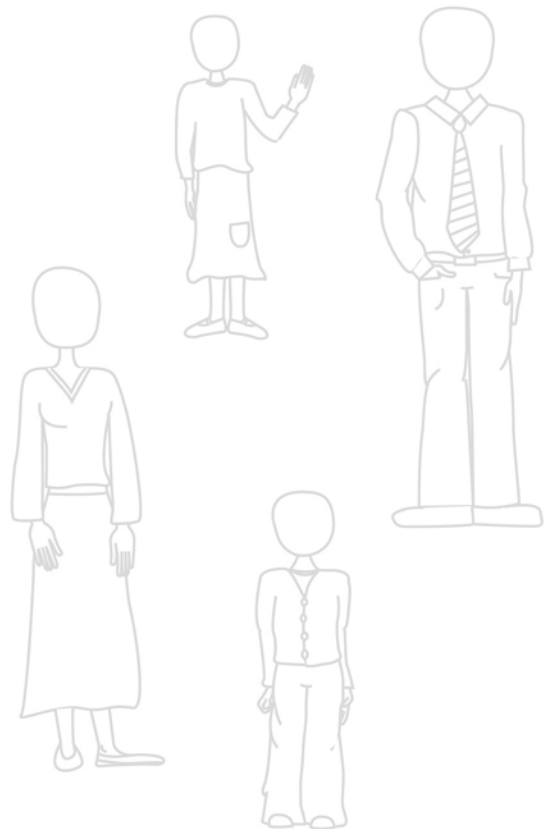

5  Listen to the conversation. Circle the correct answer.

1 father / brother

2 sister / mother

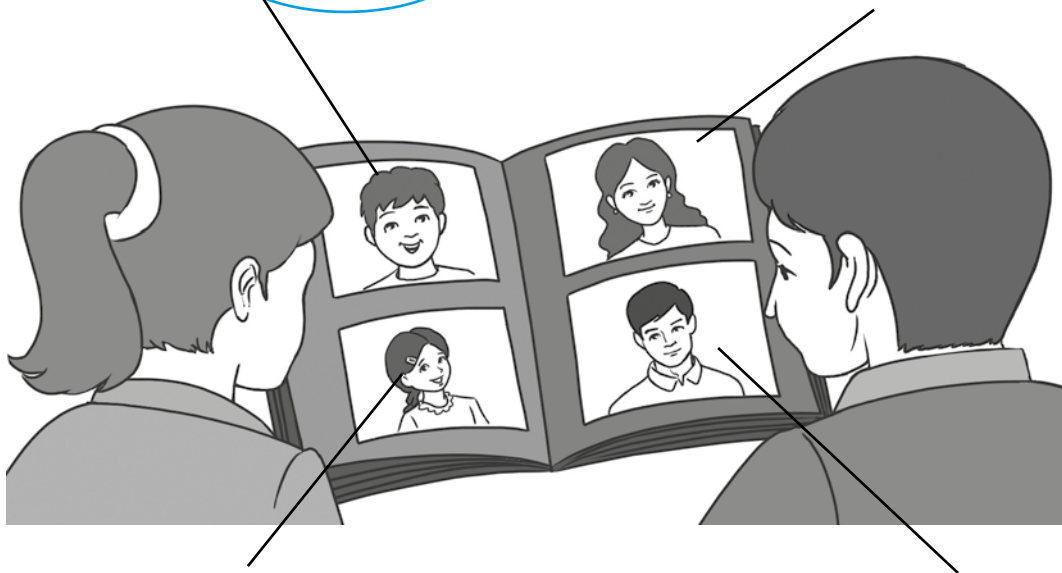

3 brother / sister

4 mother / father

6 Work in pairs. One pupil reads the question and the other looks at the picture and answers.

Who's this?



Is this your brother?



Who's this?



Is this your mother?



# 10 Revision 2

1 Find the letters and circle them.

a	s	a	p	f	a	m
b	p	s	b	m	a	b
m	a	m	s	p	b	m
f	f	m	s	p	f	a

2 Look at the pictures. What do their names begin with? Match them to the letters.

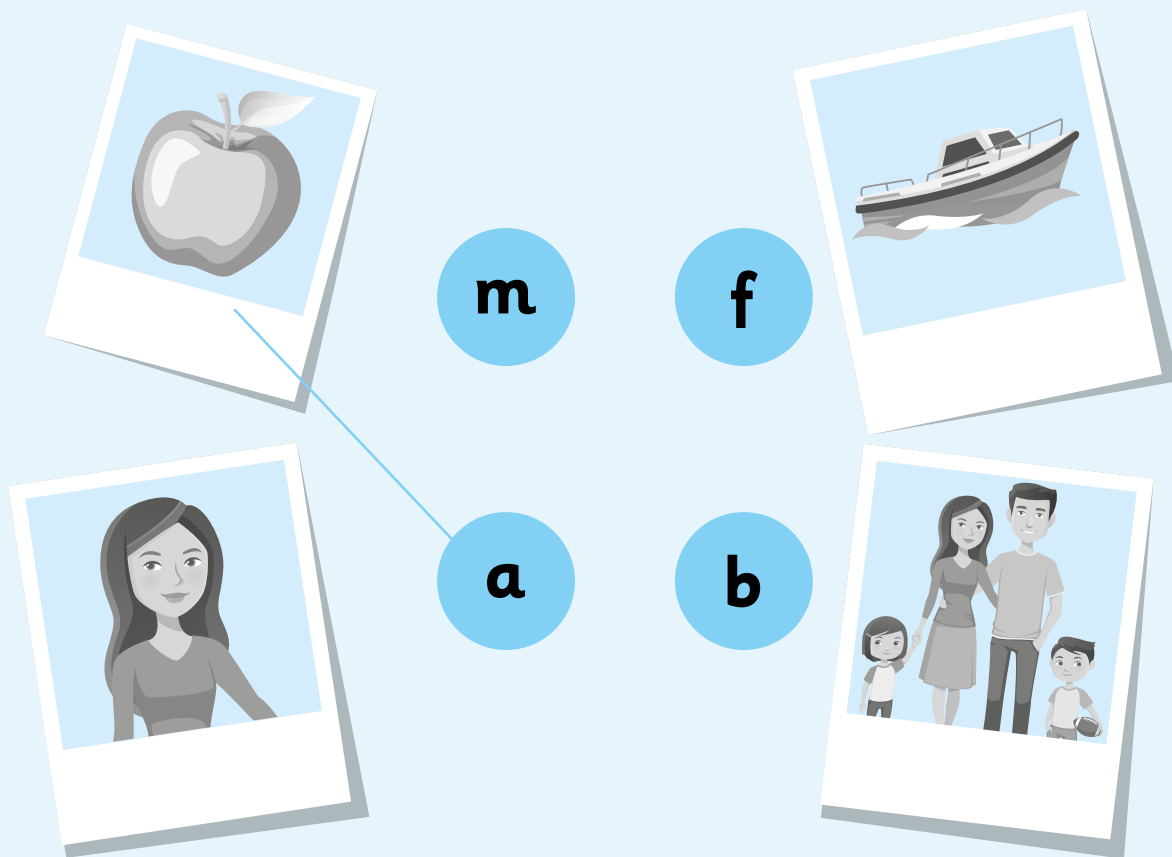

3 Read the following words. Match them with the appropriate picture.

father

boat

eye

biscuit

mother

ear

car

nose

sister

tomato

mouth

sandwich

banana

bus

brother

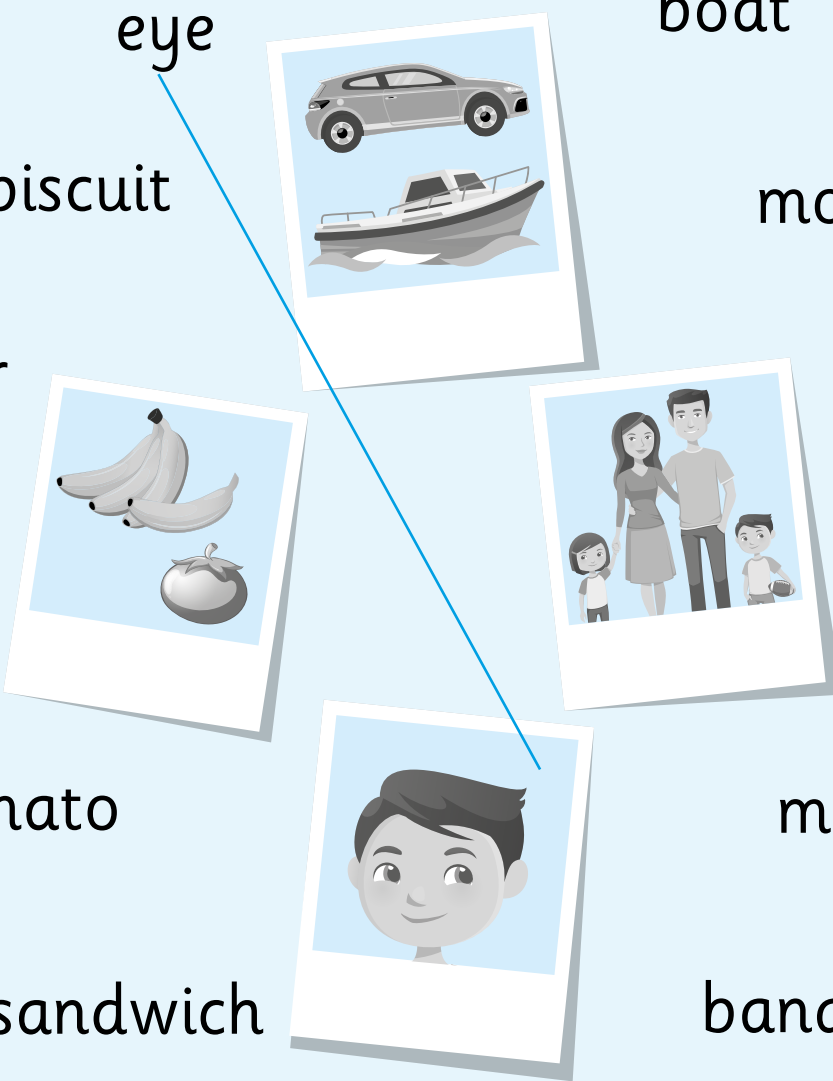

- 4  Listen to the conversations and colour the correct picture.

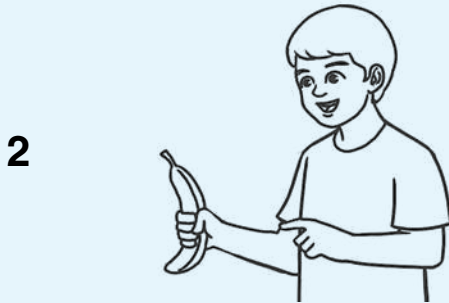
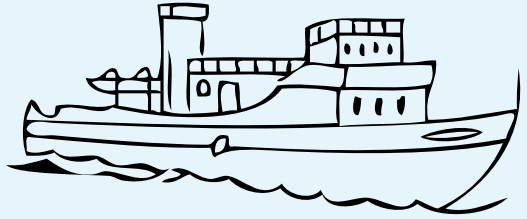
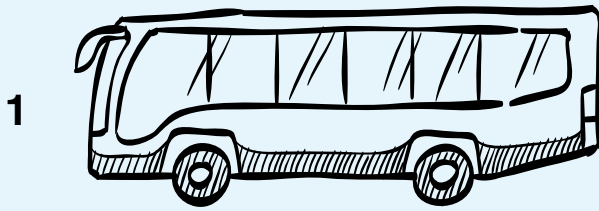

- 5 Trace and colour these pictures. Then in pairs, ask and answer questions about the objects and their colours.

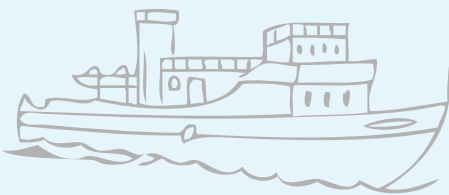
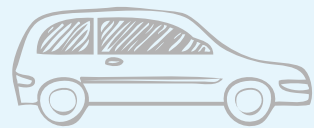

1 Trace the letter. Then, copy it five times.

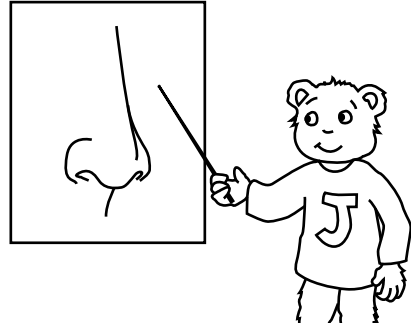
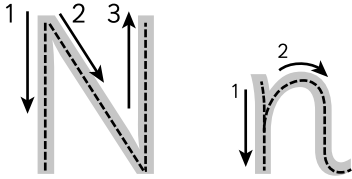

nose

Handwriting practice lines for the letter 'n'. The first row contains three uppercase 'N's: the first is blue, the second is grey, and the third is grey. The second row contains three lowercase 'n's: the first is blue, the second is grey, and the third is grey.

2 Write the letter n. Then, match the words with the pictures.

\_\_ose

\_\_ame

\_\_i\_\_e





3  Listen to the numbers and repeat them. Then, trace them.

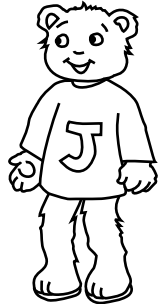
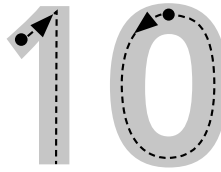
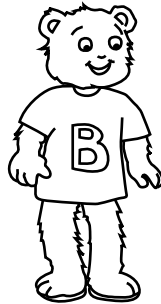
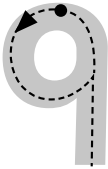
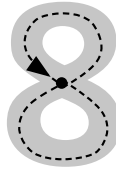

4 Trace and copy the numbers.

6 6 6

7 7 7

8 8 8

9 9 9

10 10 10

- 5  Listen to the conversations. Circle the correct answer. Then, match the sentences with the pictures.

He / **She** is seven.



He / She is six.



He / She is nine.



He / She is ten.



- 6 Work in pairs. Choose one picture each, and write the number for each person's age. Then, ask and answer questions about the other picture.

sister

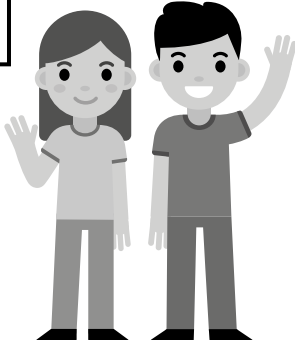

Sam

Ali

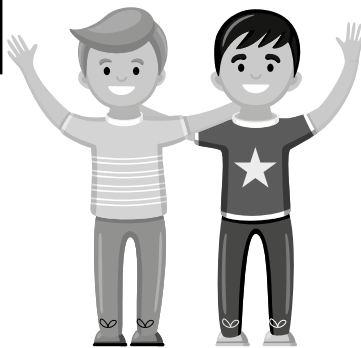

brother

1 Trace the letters. Then, copy them twice.

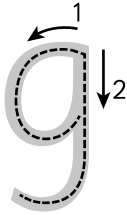
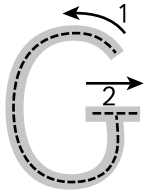

girl

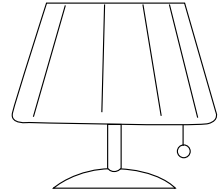
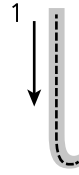
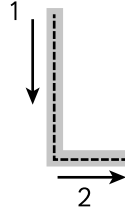

lamp



2 Write **g** or **l**. Then, choose two words and draw their picture.

\_\_reen    \_\_amp    \_\_irl    ba\_\_    penci\_\_

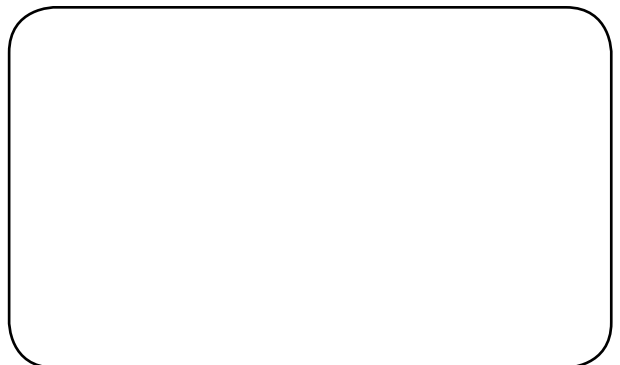
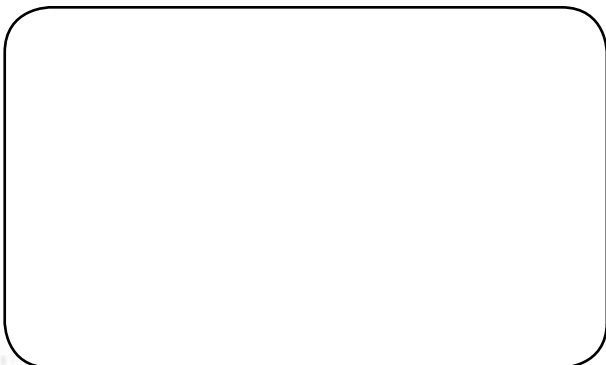

3 Trace the picture.



4  Listen and colour.

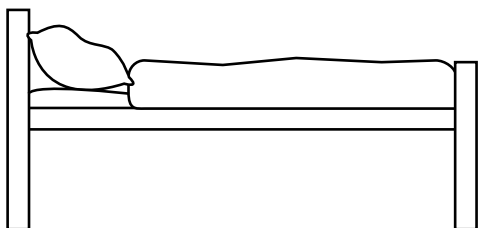
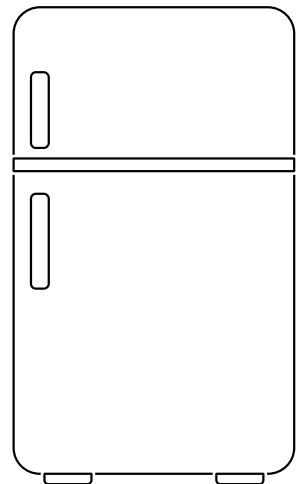
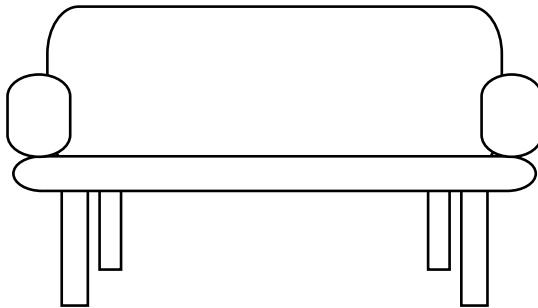
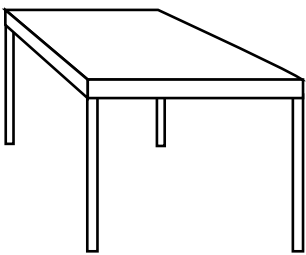

- 5  Listen to the conversation. What objects are mentioned? Draw and colour them in the picture below.

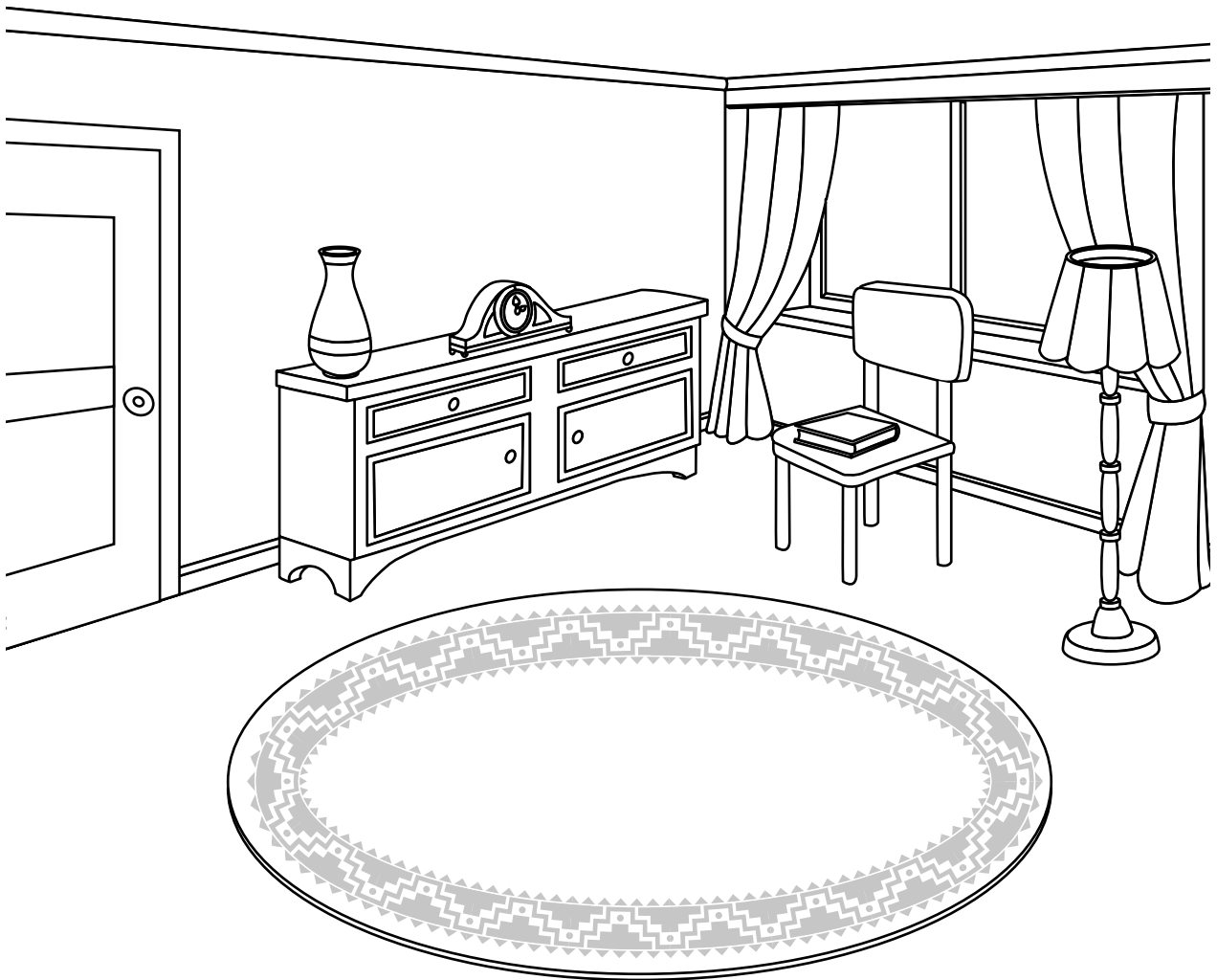

- 6 In the picture above, colour the following objects. Then in pairs, ask and answer questions about the colours of these objects.

lamp    chair    book    door

# 13

## My body

1 Trace the letters. Then, copy them twice.

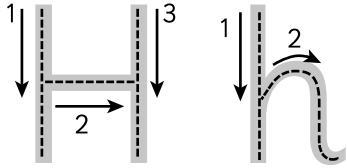

head

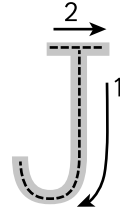

jump

Hh Hh

Jj Jj

2 Circle the beginning sound for each picture.



h f j m    b g a j    m h g l    f p n h

3 Read and circle the correct picture.

Clap your

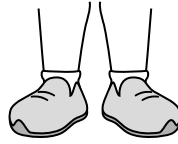

Stamp your

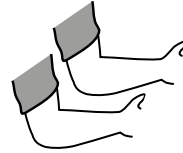
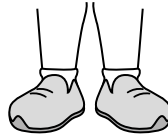

Shake your



Open your



Close your

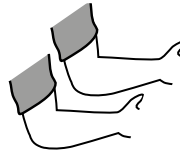

4 Read and circle the words related to the parts of the body.

black

arm

clap

bag

fridge

six

green

leg

hand

desk

mother

stamp

girl

biscuit

red

foot



- 5  Listen to the conversations. Write the correct words from the box.

Yes, it is    head    it isn't    it is    hand

Is it a **head**?

Yes, it is.

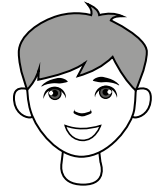

Is it a mouth?

Yes, \_\_\_\_\_.



Is it a foot?

No, \_\_\_\_\_. It's a \_\_\_\_\_.



Is it a leg? \_\_\_\_\_.



- 6 Work in pairs. Draw parts of the body from the box below. Ask and answer questions about the drawings.

arm    head    leg    foot    hand

# 14 What's that?

1 Trace the letters. Then, copy them twice.

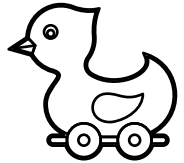
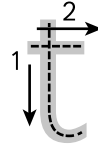
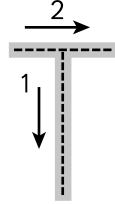
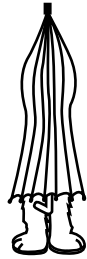
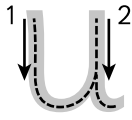
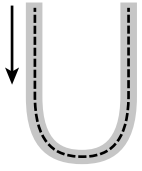

umbrella

toy

U u U u

T t T t

2 Find and circle **u** or **t**. Then, complete the words and colour the pictures.

n m **u** h s b\_\_s

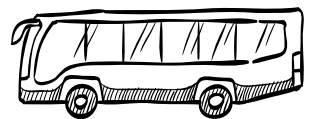

b t f l j \_\_oma\_\_o



3 Trace the picture.

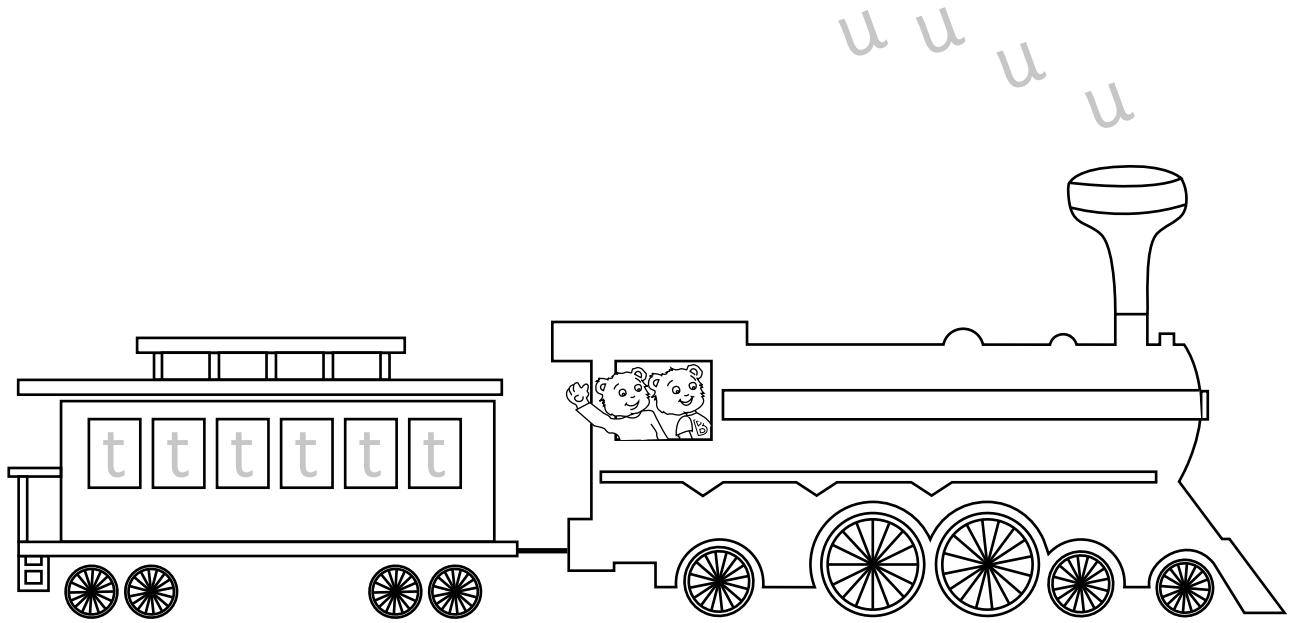

4 Circle the correct answer.



big / small



big / small



big / small

5  Listen to the conversation and colour the objects.

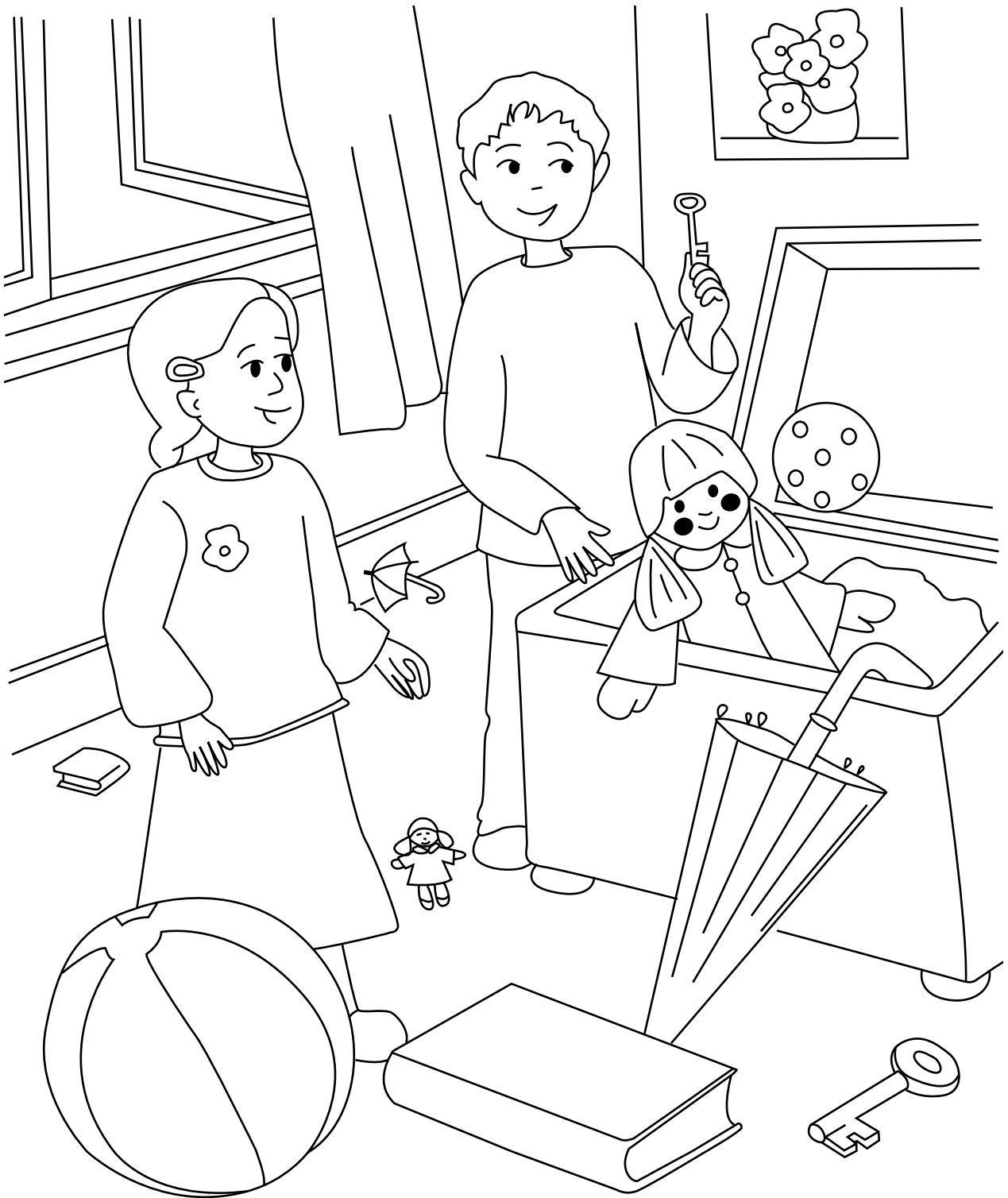

6 Colour the rest of the objects in the picture above. Work in pairs, asking and answering questions about the objects.

# 15 Revision 3

1 Circle the word that has the following beginning sounds.

**j** girl yellow **jump**

**h** white house touch

**t** ten foot sit down

**n** small hand name

**g** bag apple green

**l** leg hello ball

**u** bus computer umbrella

2 Look at the chart below. Colour the picture. Then, look at your partner's picture. Is it the same?

**u**  
blue

**h**  
red

**l**  
yellow

**g**  
green

**n**  
white

**t**  
black

**j**  
blue

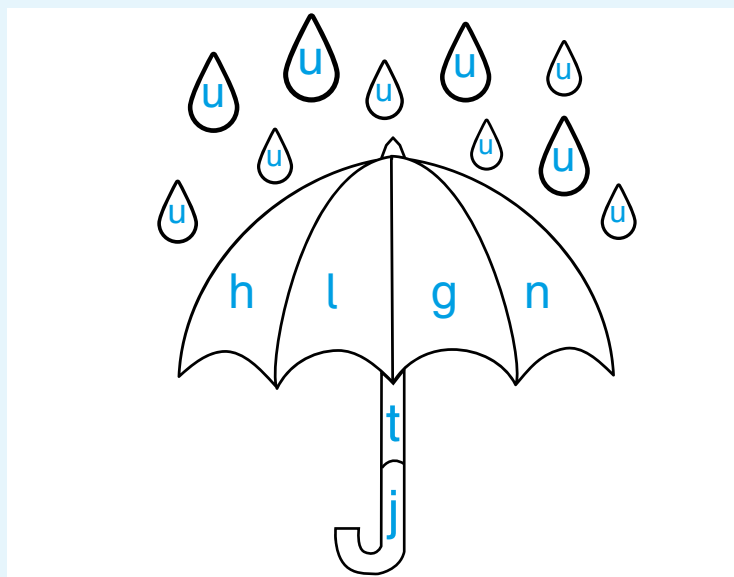

3 Trace the following words. Then, match them with the pictures.

bed

10

ball



leg

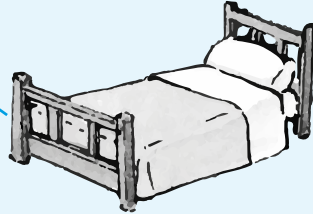

foot

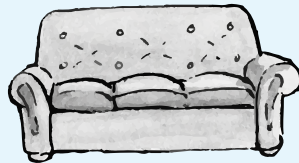

ten



big

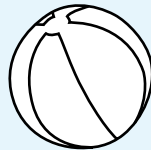

sofa



doll

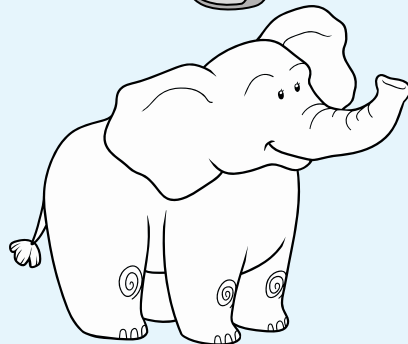

- 4  Listen to the conversation and tick (✓) the correct answers.

How old is Dan's sister?

6

7

8

What colour is the ball?

green

blue

black

What is big?

the doll's  
head

the doll

the doll's  
leg

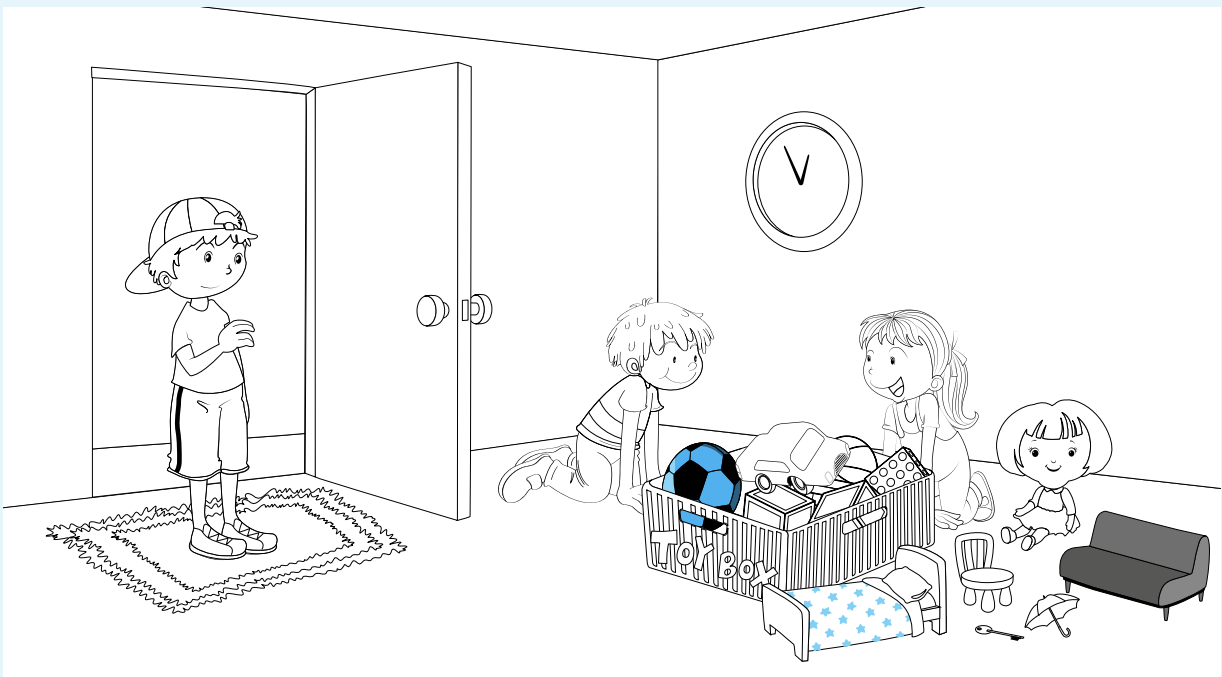

- 5 Colour the following objects in the picture above. Work in pairs, asking and answering questions about these objects.

chair

umbrella

key

bed



# 16 Our clothes

1 Trace the letters. Then, copy them twice.

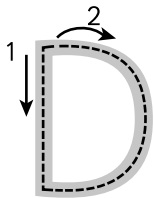

desk

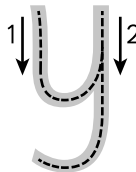
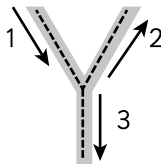
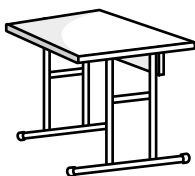
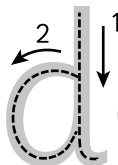

yellow

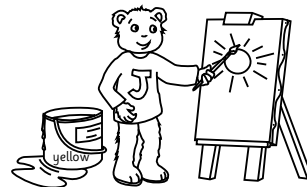

D d D d

Y y Y y

2 Write **d** or **y**. Then, colour the pictures.

\_\_ellow

\_\_oor

re\_\_

to\_\_

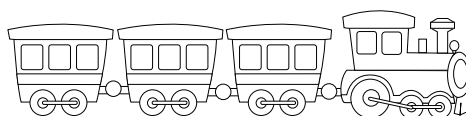
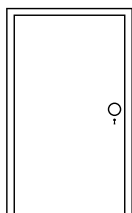

3 Find these clothes in the picture below and circle them. Say their names.

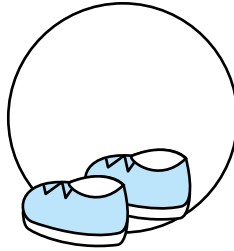
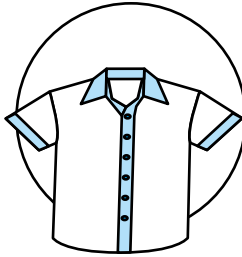

4  Listen to the conversations. Colour the clothes.



5 Work in pairs. Colour the clothes of the girl and the boy and tell your partner about them.

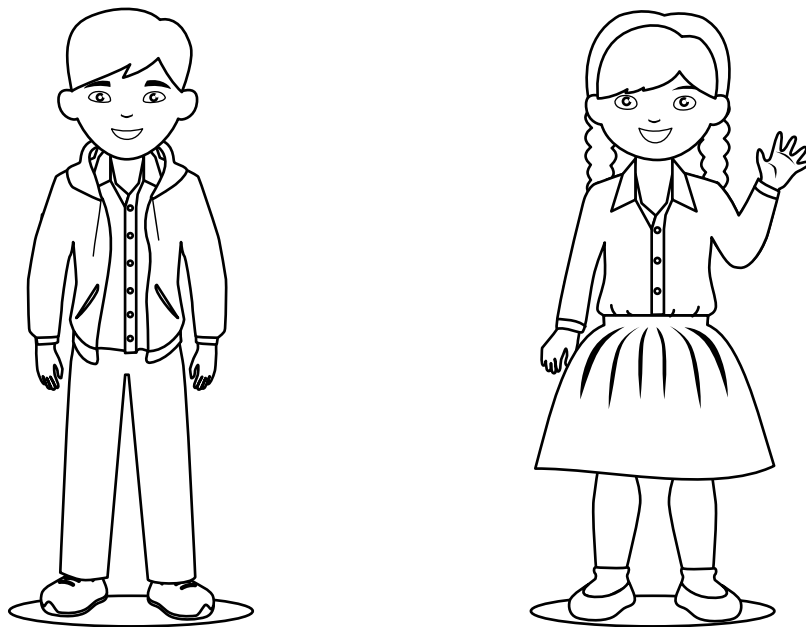

# 17

## Where is it?

1 Trace the letters. Then, copy them twice.

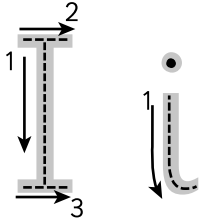

in

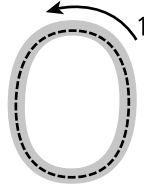

on

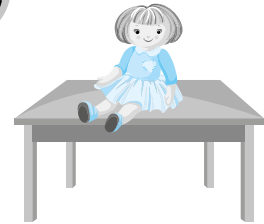
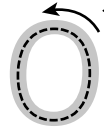

**I** i I i

**O** o O o

2 Write the words under **i** or **o**.

big    doll    six    sit    box    on

i	o
_____	_____
_____	_____
_____	_____

3 Trace the picture.

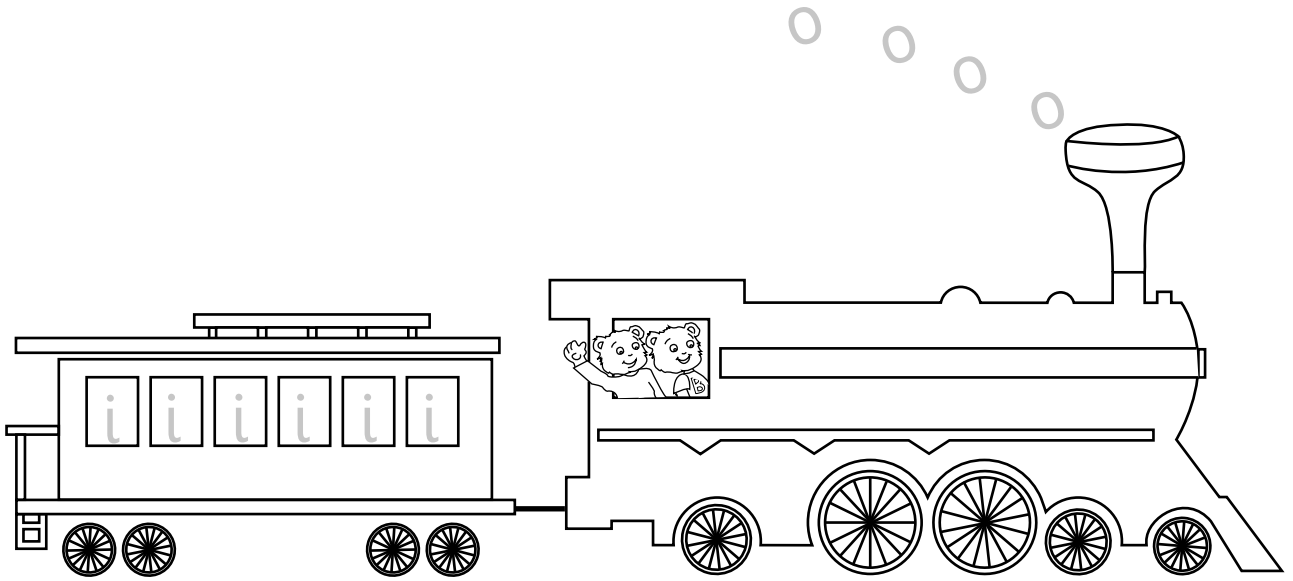

4  Listen to the sentences and colour the correct picture.

1

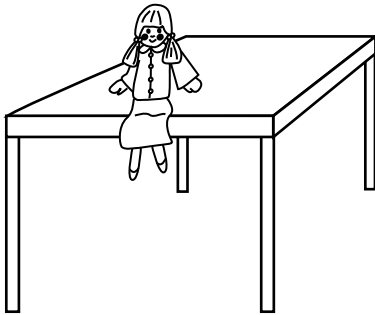

2

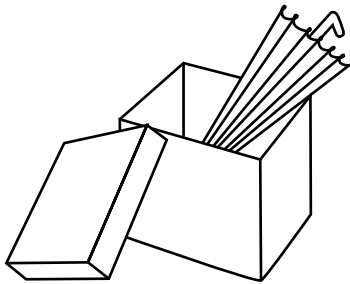

3

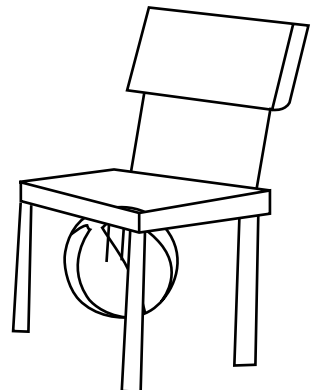
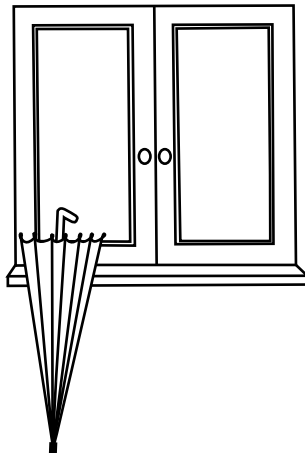
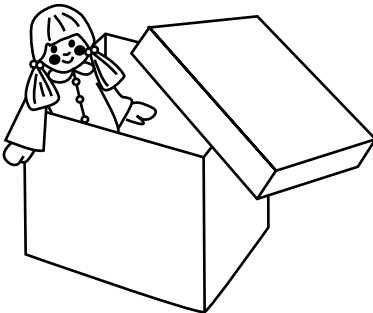
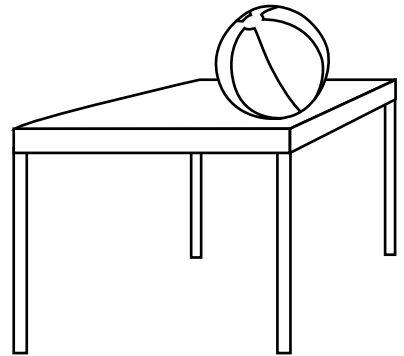

- 5  Listen to the sentences. Follow the instructions, draw and colour.

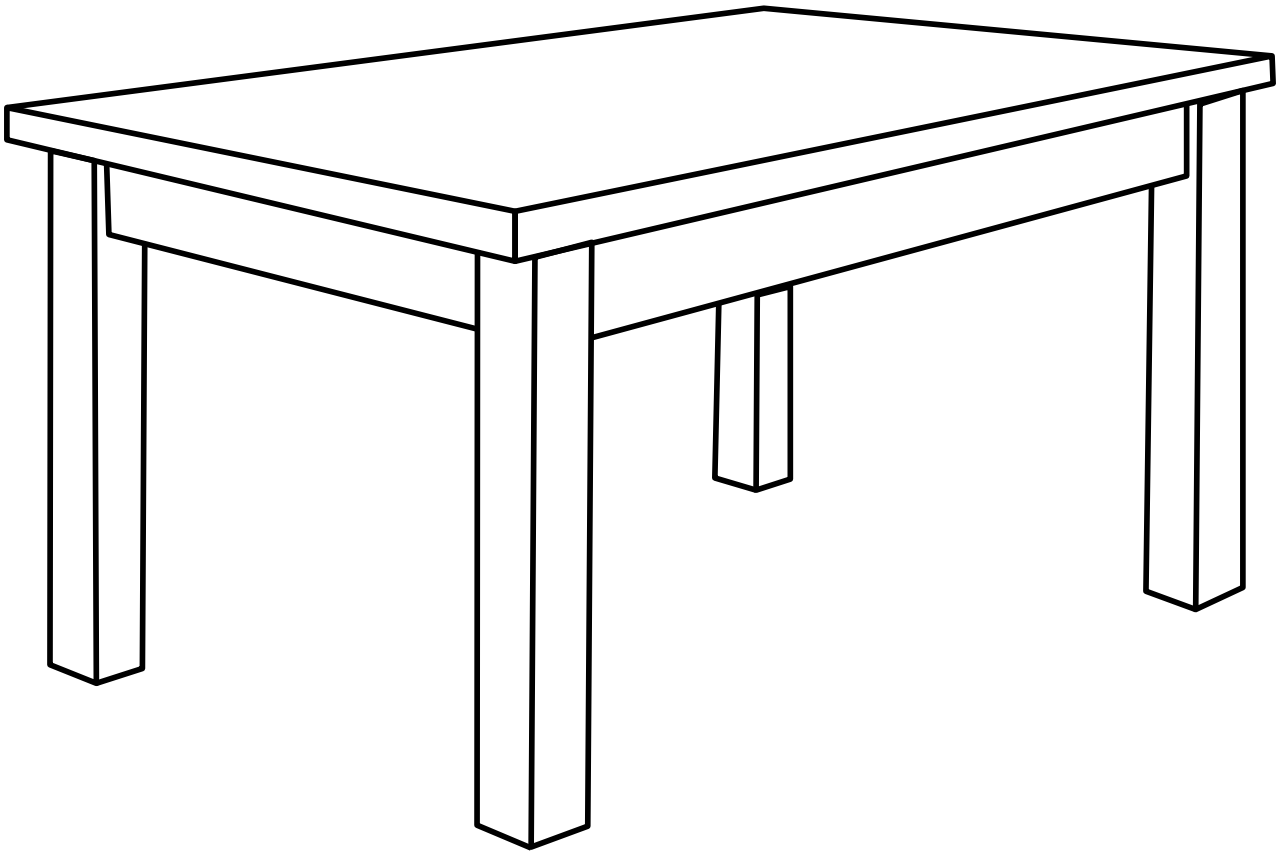

- 6 Look at the picture above. Draw and colour other objects. In pairs, tell your partner about the location and colour of these objects.

1 Trace the letters. Then, copy them twice.

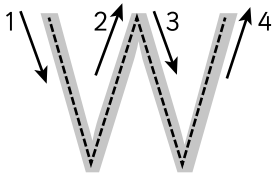

water

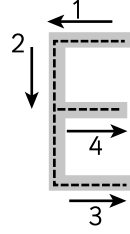
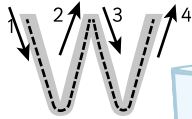

egg

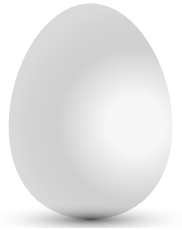

Handwriting practice lines for the letter 'W'. The first line shows a blue 'W' and a grey 'W' on a set of three lines (top, middle-dotted, bottom). The second line shows a blue 'w' and a grey 'w' on the same set of lines. Below this is another set of three lines for independent practice.

Handwriting practice lines for the letter 'E'. The first line shows a blue 'E' and a grey 'E' on a set of three lines (top, middle-dotted, bottom). The second line shows a blue 'e' and a grey 'e' on the same set of lines. Below this is another set of three lines for independent practice.

2 Circle **e** and cross out **w** in the following words.

~~w~~indow      yellow      dress

desk      sandwich      umbrella



3 Cross out the picture that is not related to food.

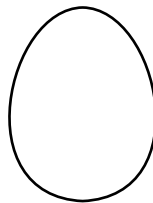
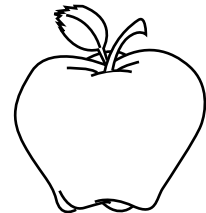
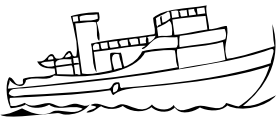
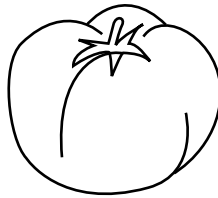
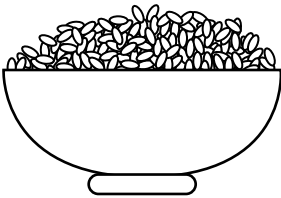
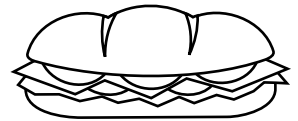
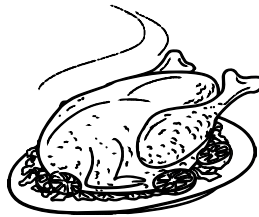
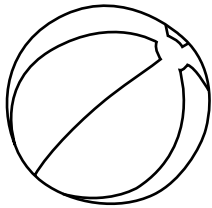
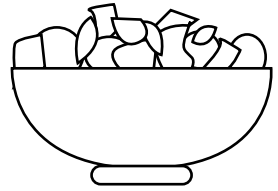
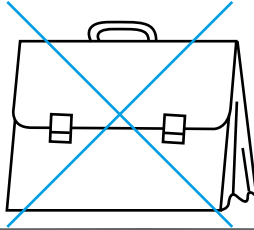
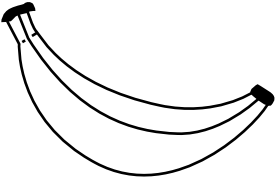

4 Choose the food that you like and complete the sentence.

salad    rice    chicken    ice cream

I like \_\_\_\_\_.

- 5  Listen to the conversation. Draw the food on the table.

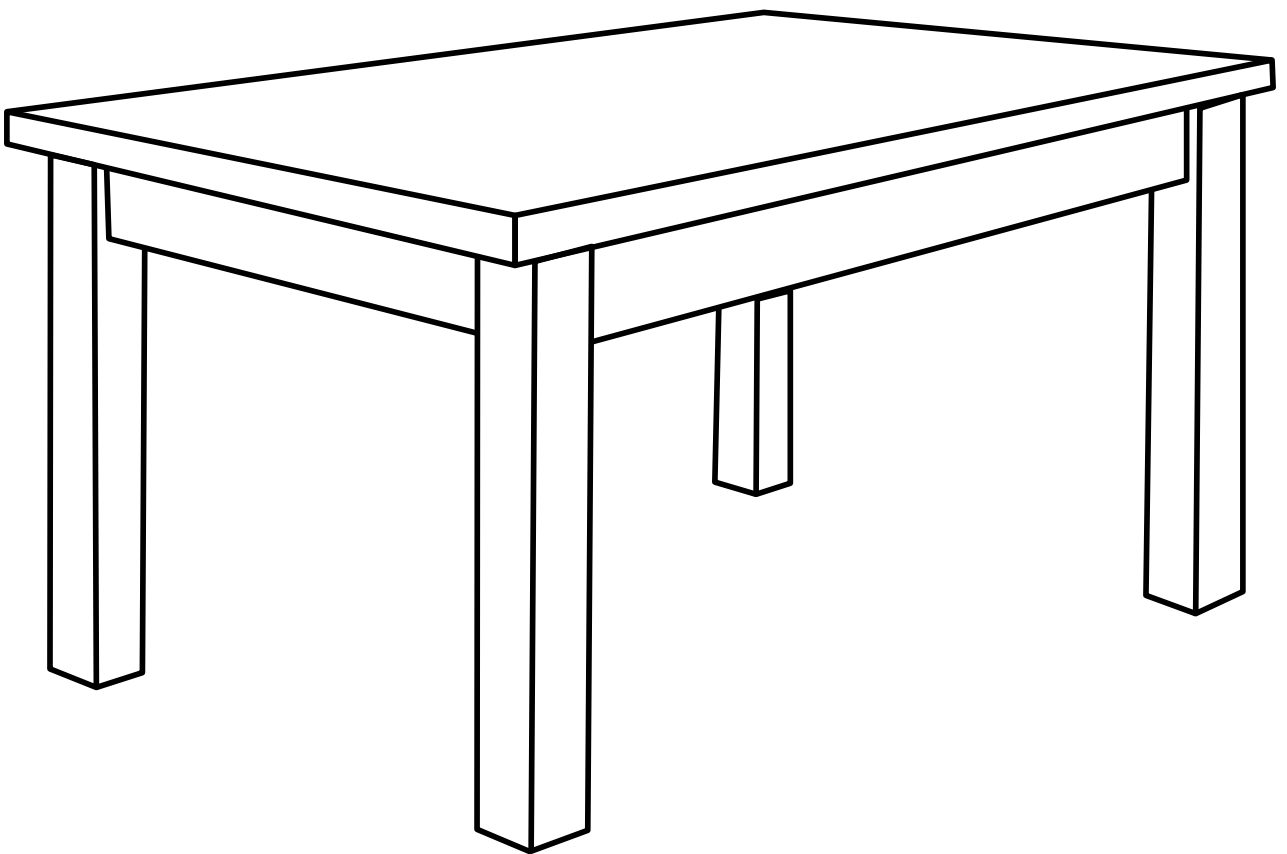

- 6 Add more food on the table above. In pairs, ask and answer questions about what you like and how many food items there are.

# 19

# Animals

1 Trace the letters. Then, copy them twice.

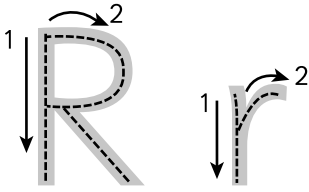

rabbit

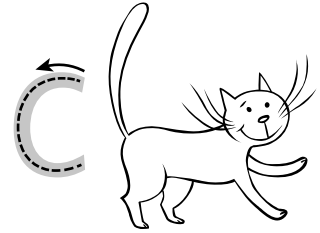

cat



2 Find and circle two words beginning with **r** and two words beginning with **c**. Then, write the words.

b **r** i c e d y r e d m r \_\_\_\_\_ r \_\_\_\_\_

u h c a r f i e c a t c \_\_\_\_\_ c \_\_\_\_\_

3 Trace the picture.

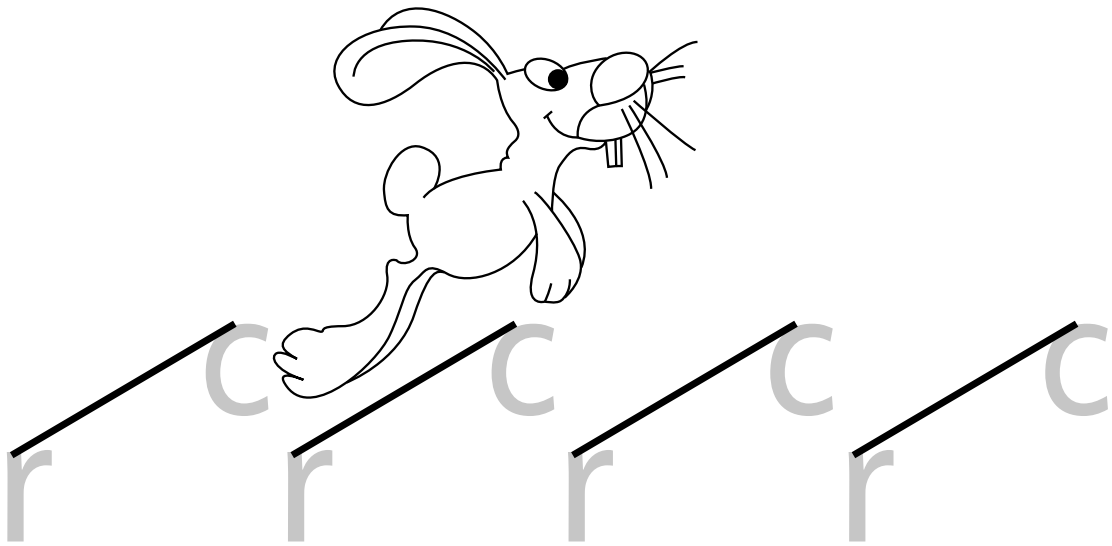

4 Trace the following words. Then, match them with the pictures.

dog

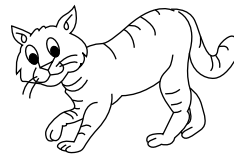

horse



rabbit



cat

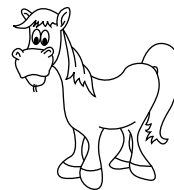

bird

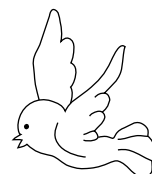

- 5  Listen to the conversation. Colour the animals that the boy can see.

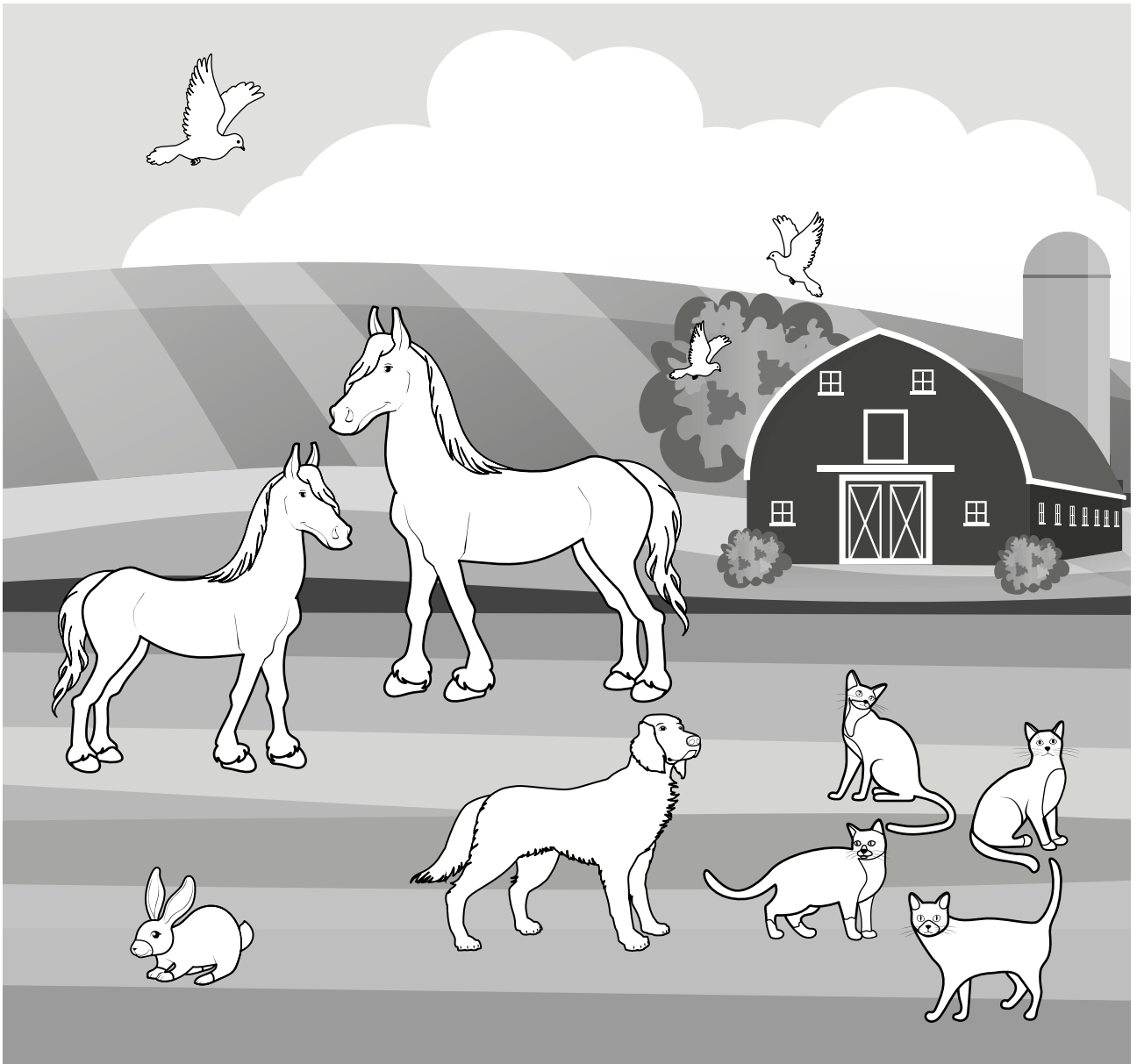

- 6 Work in pairs. Ask and answer questions about the other animals in the picture above.

# 20 Revision 4

- 1 Complete the words with the letters from the box. Then, choose two words and draw their picture below.

r o d w y e

sand\_\_ich

f\_\_idge

\_\_oll

bo\_\_

d\_\_g

h\_\_llo

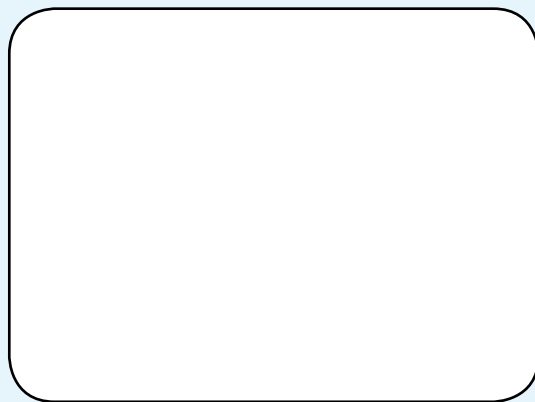
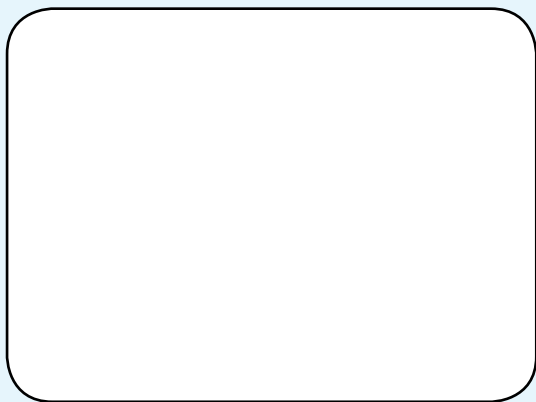

- 2 Cross out the words that do not have the following sounds.

w yellow water ~~umbrella~~

c clap close shoes

d ball door dog

o box doll bag

y boy jacket toy

i sister biscuit salad

3 Read the following words. Match them with the appropriate picture.

horse

shirt

salad

rice

bird

jacket

cat

egg

skirt

water

chicken

shoes

dress

ice cream

rabbit

dog

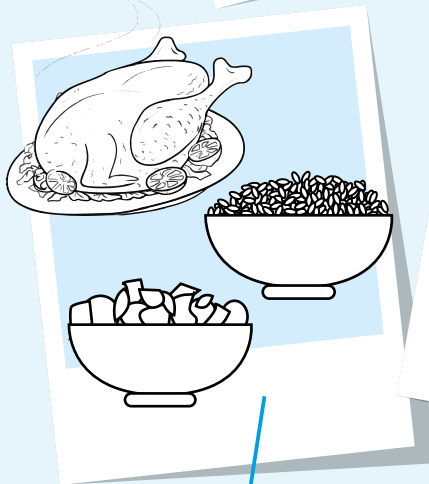
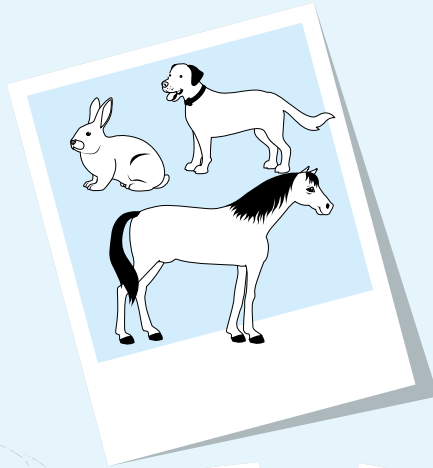

4



Listen to the conversations and circle the correct answer.

1

a

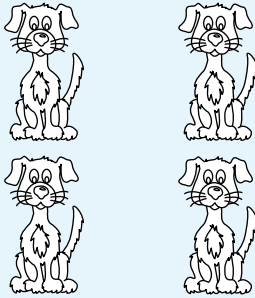

b

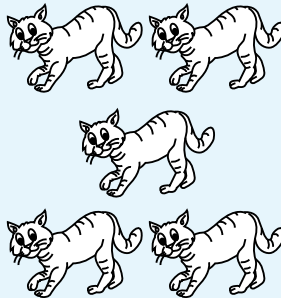

c

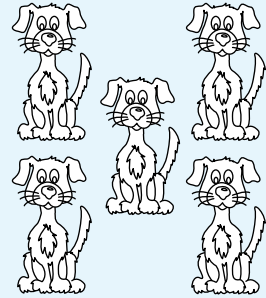

2

a

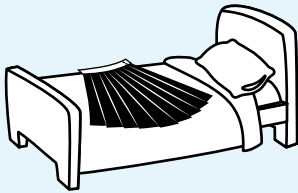

b

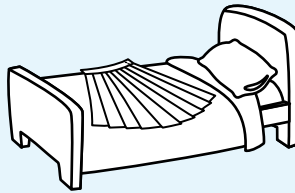

c

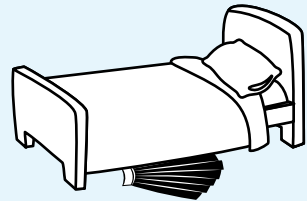

3

a



b

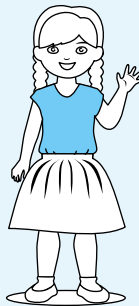

c



4

a

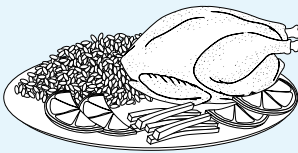

b

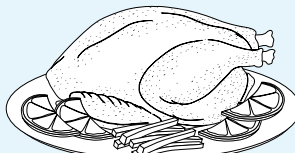

c

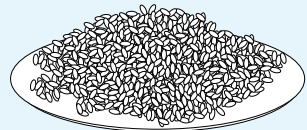

5

Choose other pictures from Exercise 4. Work in pairs asking and answering questions about them.



1 Trace the letters. Then, copy them twice.

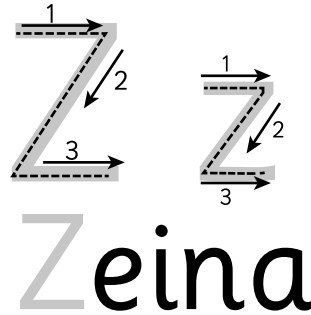
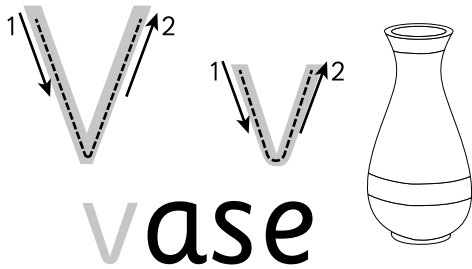

Handwriting practice lines for the letter 'v' and 'z'. The first row shows 'V v' and 'V v' on a set of three lines (top, middle, bottom). The second row shows 'Z z' and 'Z z' on the same set of lines.

2 Write **v** or **z**. Then, choose two words and draw their picture.

fi\_\_e    \_\_ase    se\_\_en    \_\_eina

3 Look at what Zeina and Hassan have and do not have. Trace lines below and ask the questions. Then in pairs, answer with **Yes, it is** or **No, it isn't**.

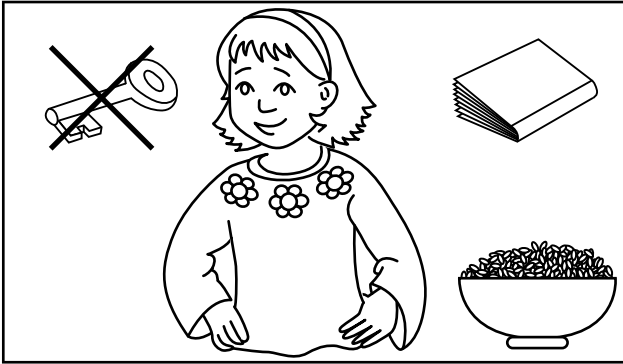

Is that

Zeina's

Hassan's

4  Listen to the conversations. Match the characters with what they have.

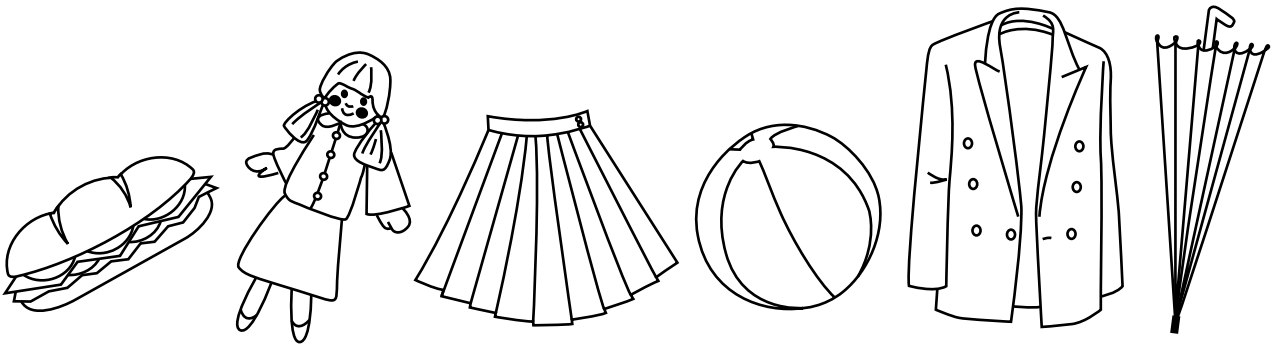

5 Work in groups of four. Draw three objects in the box below. Decide which object belongs to which member of your group. Have your group guess.



1 Trace the letters. Then, copy them twice.

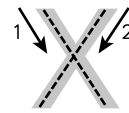
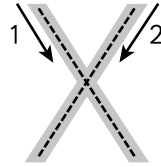
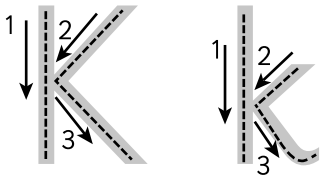

kitchen

box

K k K k

X x X x

2 Write the words under **k** or **x**.

desk book six box key

k	x
_____	_____
_____	_____
_____	_____

3 Read the questions. Tick (✓) the correct picture. Say where the people are.

## Where's Father?

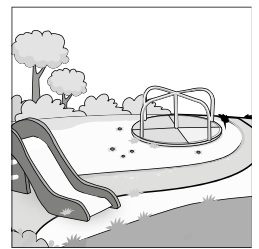
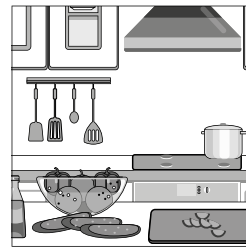
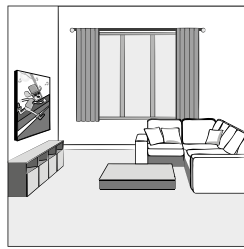



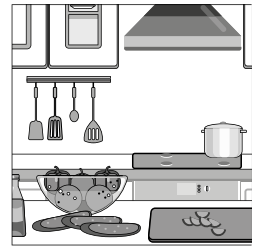
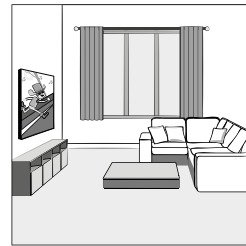

## Where's Mother?





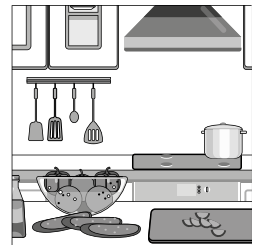
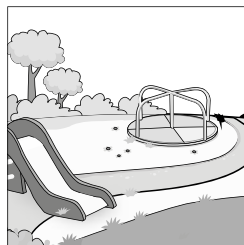

## Where's Sister?

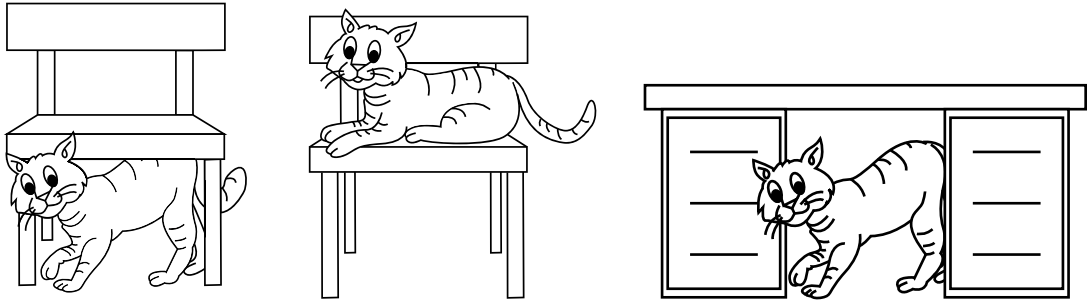

4  Listen to the sentences and colour the correct item.

1



2

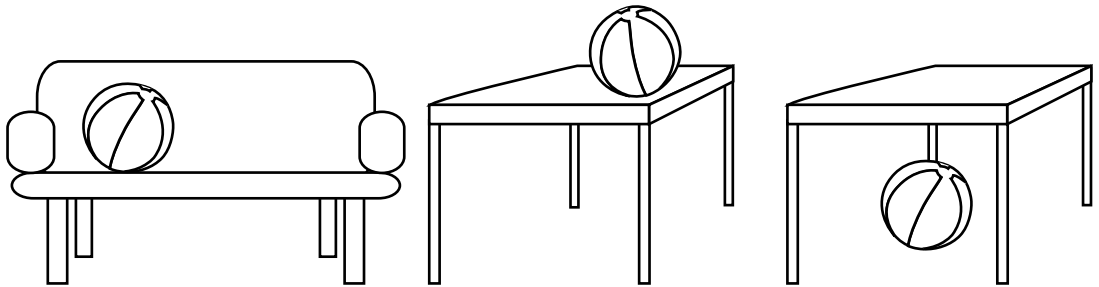

3

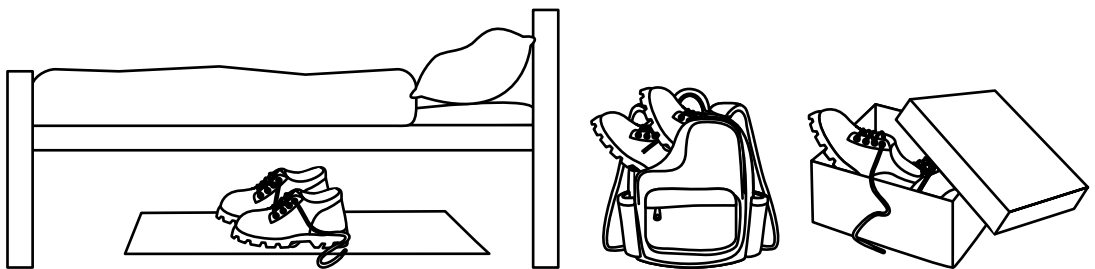

5 Work in pairs. Look at the pictures above that are not coloured. Give your partner instructions to colour the correct item.

1 Trace the letter. Then, copy it five times.

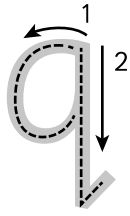
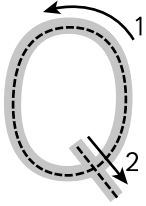

quack

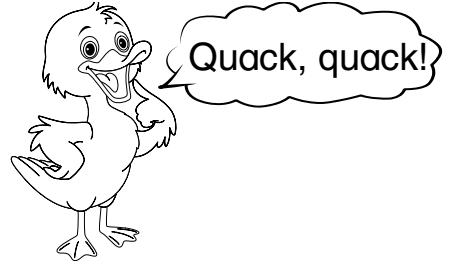

Handwriting practice lines for uppercase letter Q. The first row shows three Qs: the first is blue with a stroke order arrow, the second and third are grey. Below are two more empty rows of handwriting lines.

Handwriting practice lines for lowercase letter q. The first row shows three qs: the first is blue with a stroke order arrow, the second and third are grey. Below are two more empty rows of handwriting lines.

2 Colour the q spaces. What is this drawing? Complete the word.

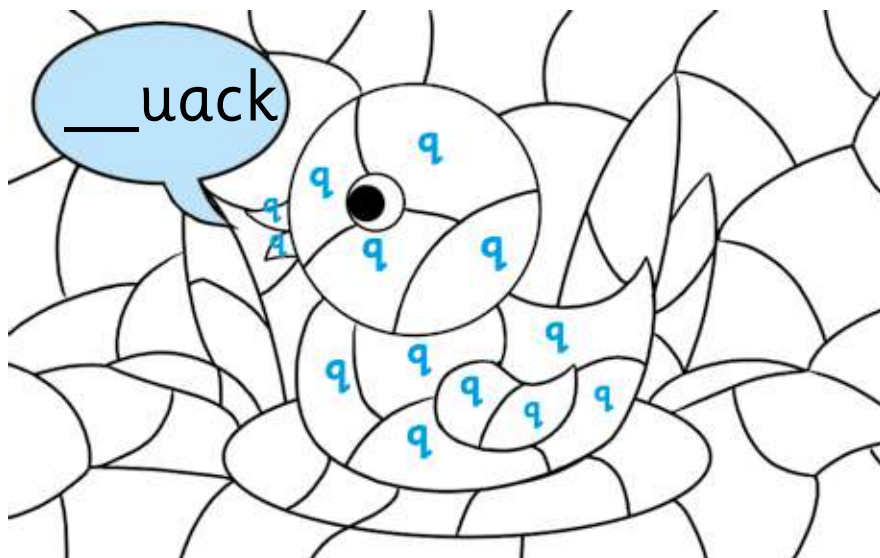



3 Trace the following words and match them to the pictures.

short

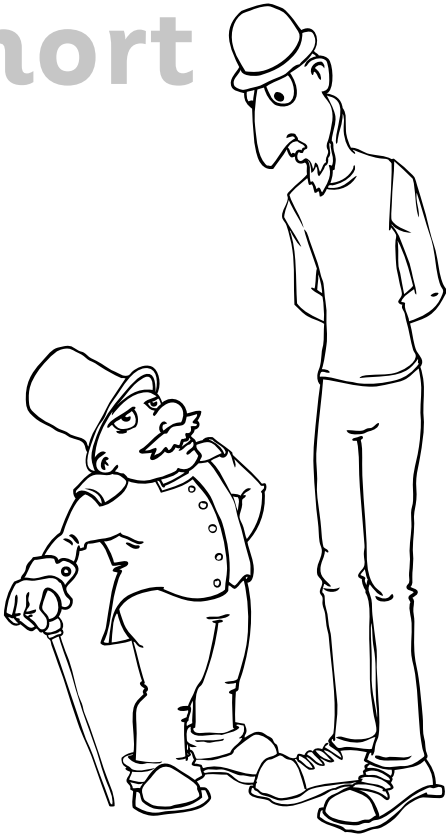

small



big

tall



4  Listen to the conversation and colour.



5 Colour Tippy and Colin. In pairs, ask and answer questions about the colour of their clothes.



2 Trace the letters and match them with the words and pictures.

v

key

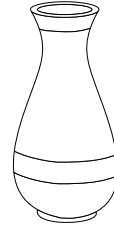

z

quack

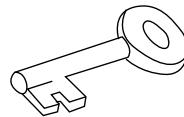

k

vase

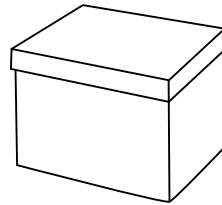

x

Zeina



q

box

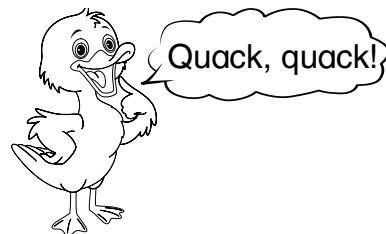

3  Listen to the conversations and colour.

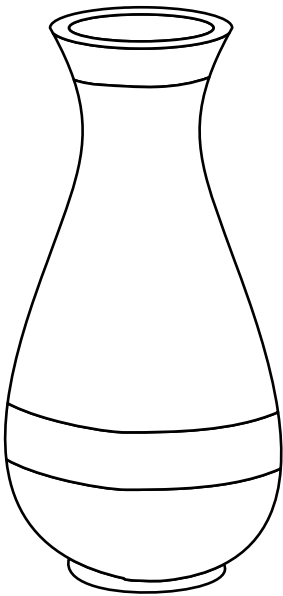
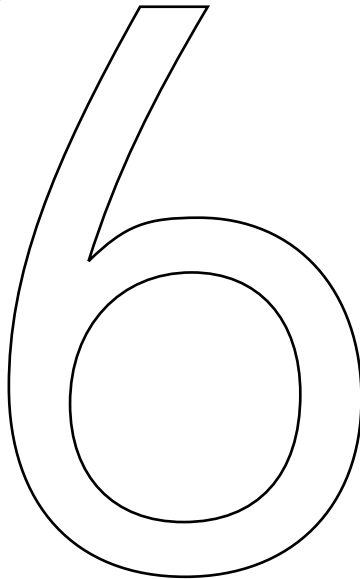
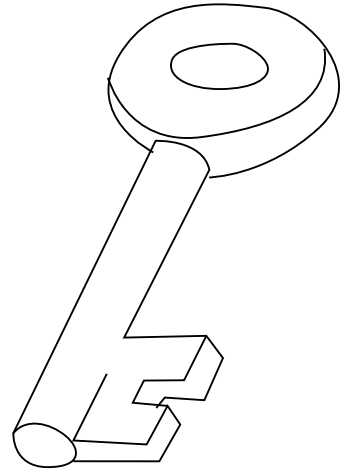

# 25 Revision 5

- 1 Trace the letters. Then, match the sentences with the pictures.

The key is in the box.



The girl is in the boat.

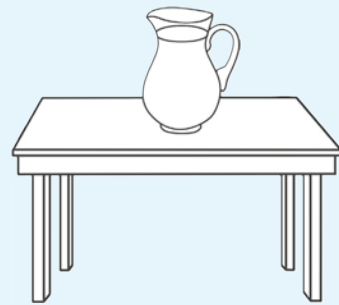

The water is on the table.



The cat is under the car.

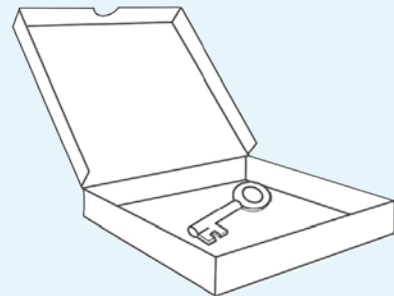

2



Listen to the conversations. Circle the correct picture. Then, choose other pictures and have the same conversations with your partner.

1

a

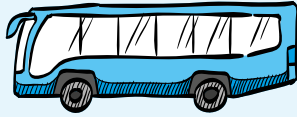

b

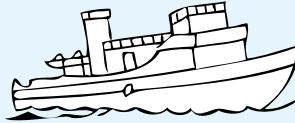

c

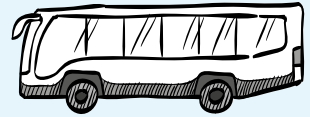

2

a



b



c



3

a



b



c



4

a

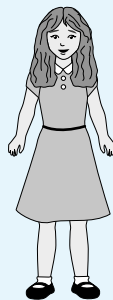

b



c

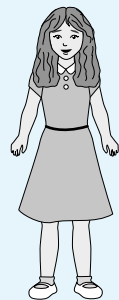

5

a



b



c



3



Listen to the sentences and colour.

1

2

3

4

5

6

7



8

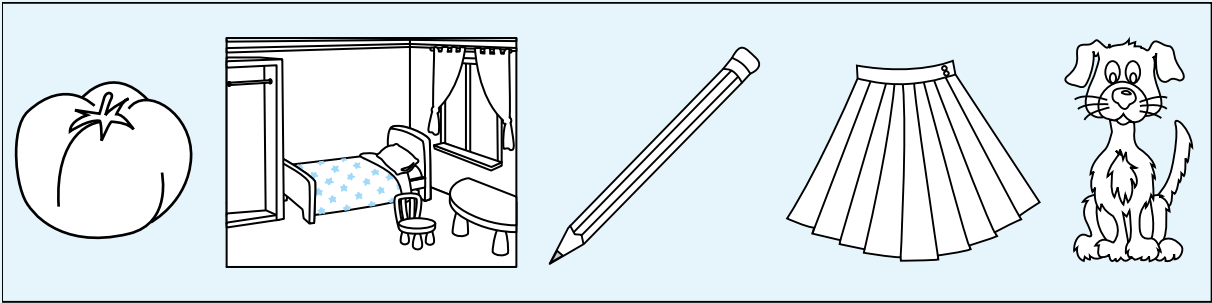

9

10

4 Draw the following items in their correct place.

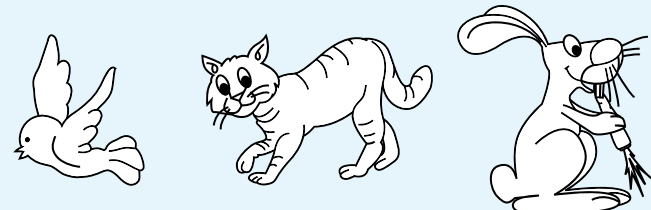

1  

2  

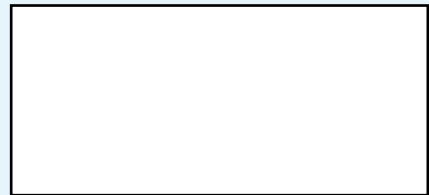
3  

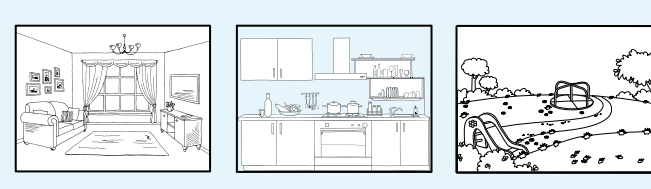
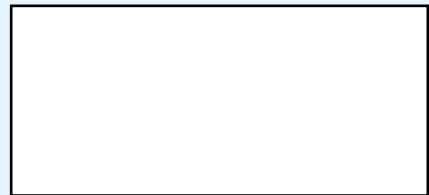
4  

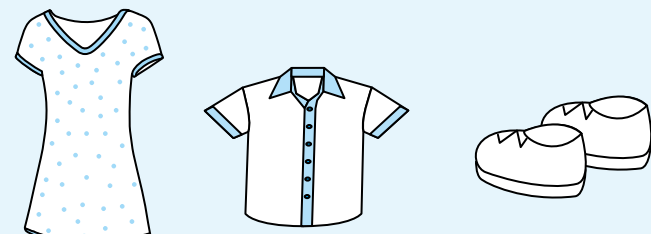
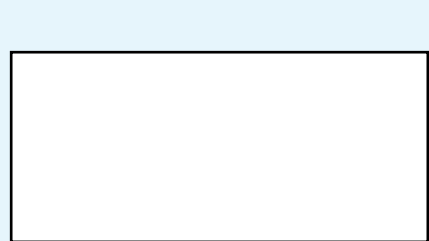
5  



5 Trace the letters and match them with the words and pictures.

f

nine

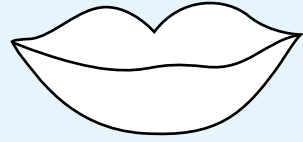

m

four

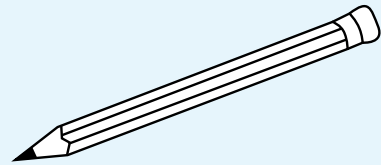

n

mouth

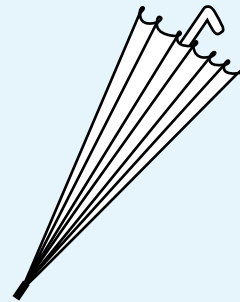

p

umbrella

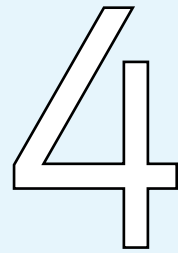

u

pencil

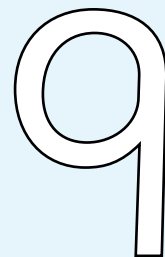

6 Draw a line from Bill and Jill to the garden. Don't touch the clouds!

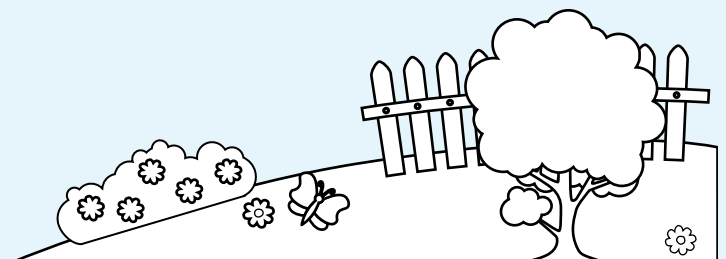
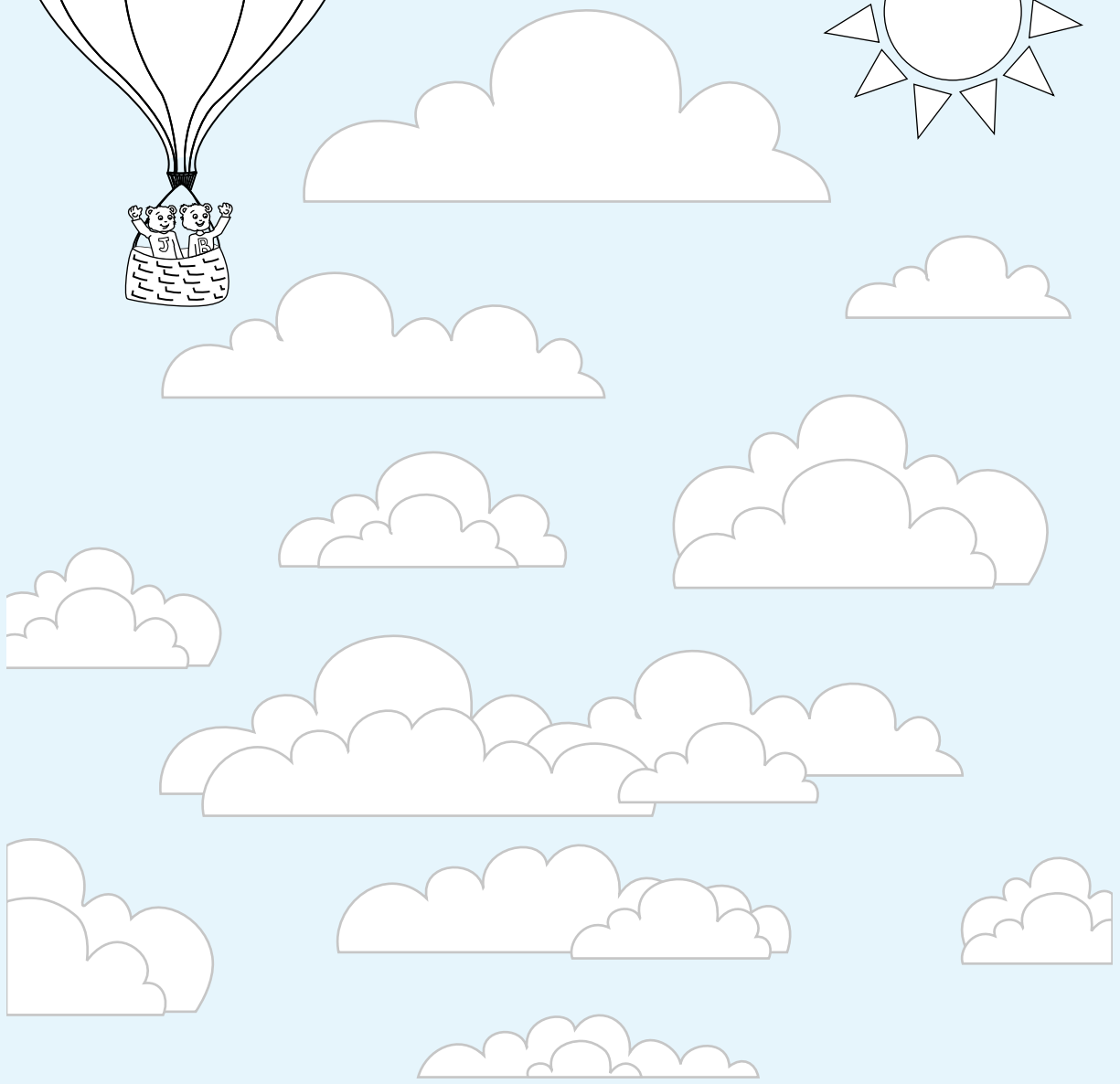
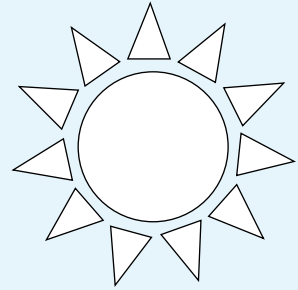

# Handwriting Practice

Trace and copy.

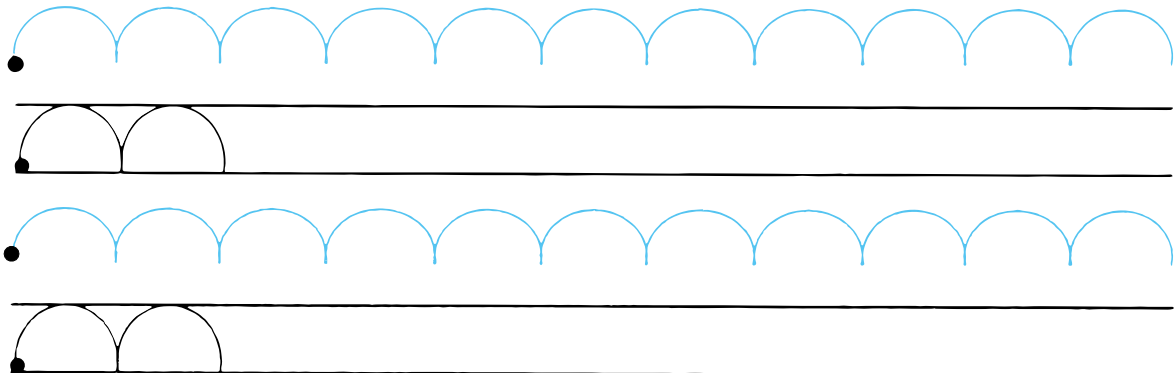
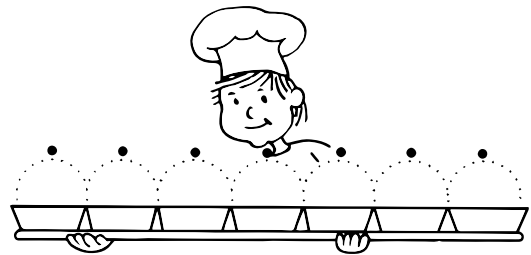
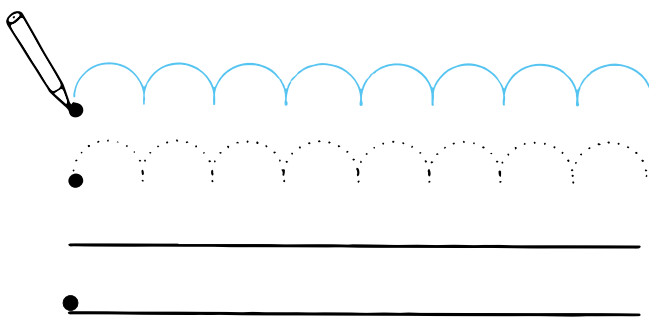
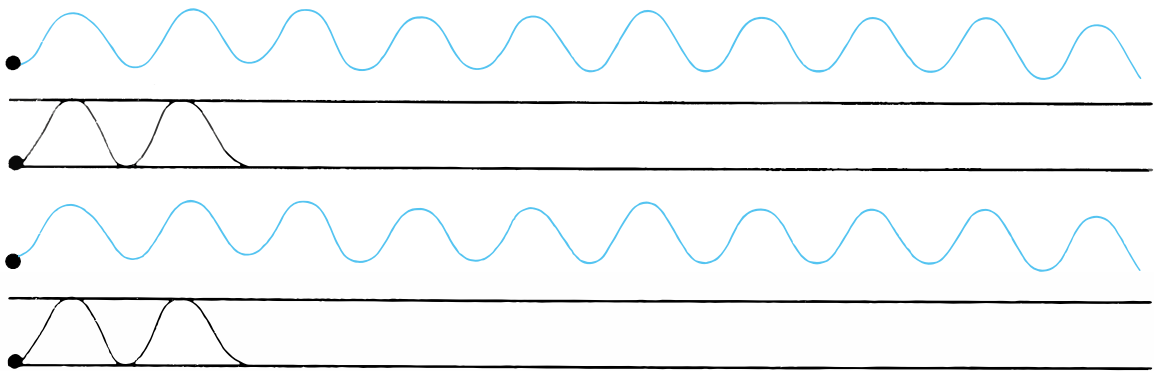
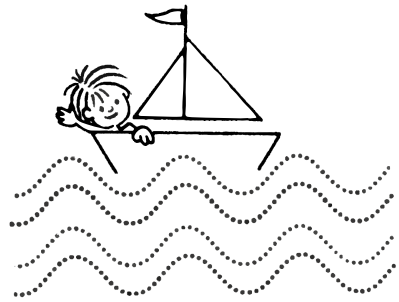
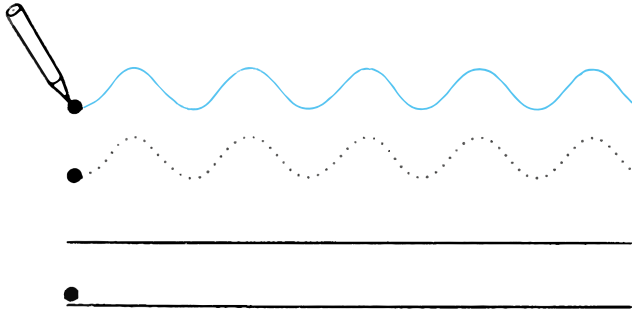

# Handwriting Practice

Trace and copy.

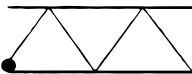
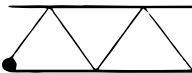
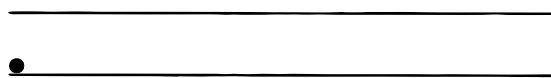
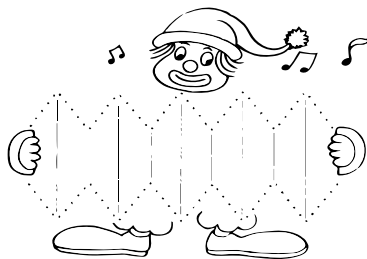
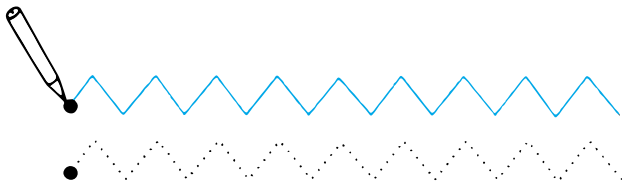
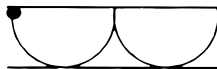
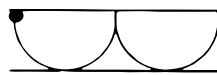
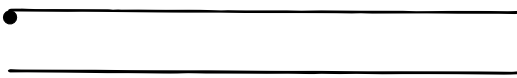
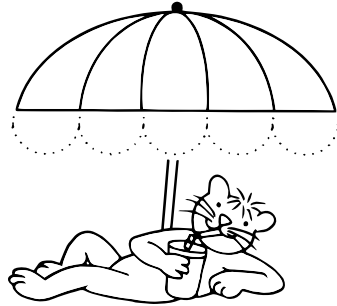
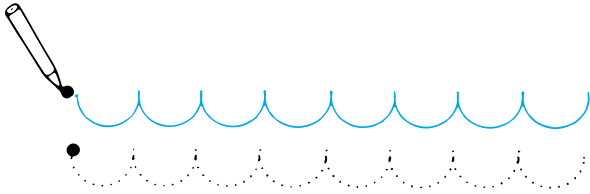

Trace and copy.

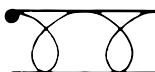
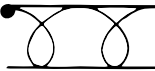
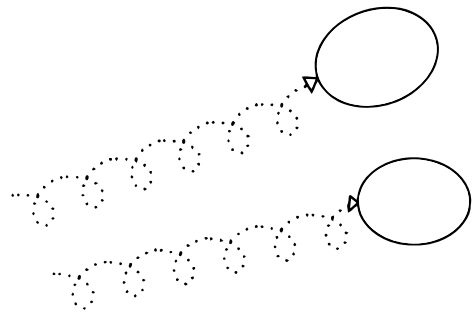
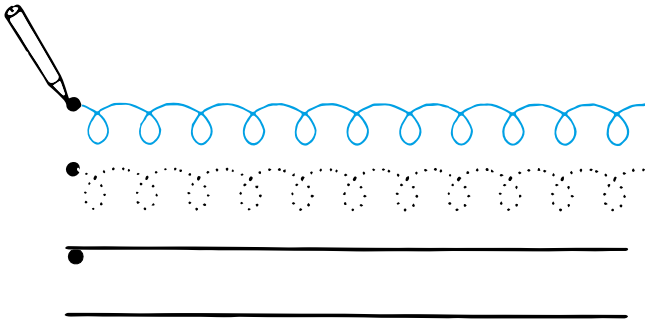
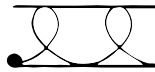
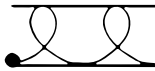
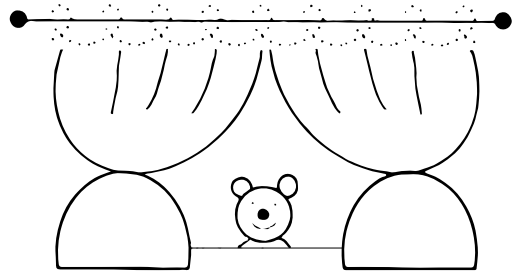
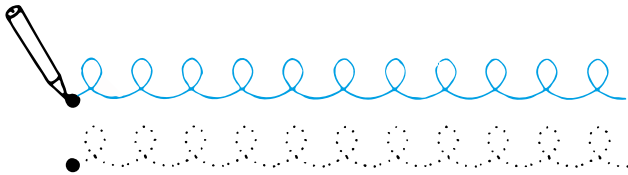

# Handwriting Practice

Trace and copy.

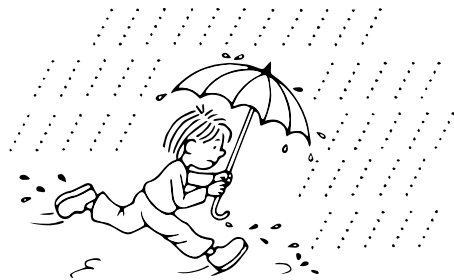
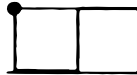
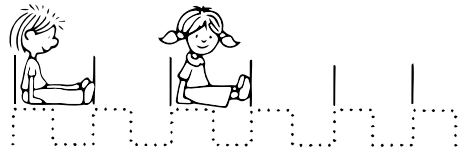
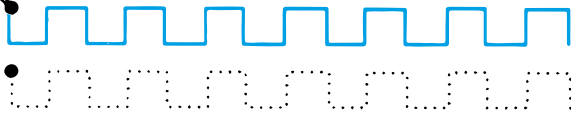

Trace and copy.

A A A

a a a

B B B

b b b

# Handwriting Practice

Trace and copy.

C C C

c c c

D D D

d d d



Trace and copy.

E E E

e e e

F F F

f f f

# Handwriting Practice

Trace and copy.

G G G

g g g

H H H

h h h

Trace and copy.

I I I

i i i

J J J

j j j

# Handwriting Practice

Trace and copy.

K K K

k k k

L L L

l l l

Trace and copy.

M M M

m m m

N N N

n n n

# Handwriting Practice

Trace and copy.

O O O

o o o

P P P

p p p

Trace and copy.

Q Q Q

q q q

R R R

r r r

# Handwriting Practice

Trace and copy.

S S S

s s s

T T T

t t t



Trace and copy.

U U U

u u u

V V V

v v v

# Handwriting Practice

Trace and copy.

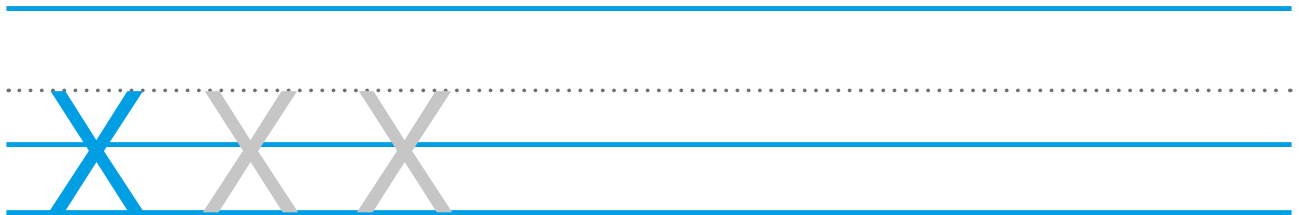
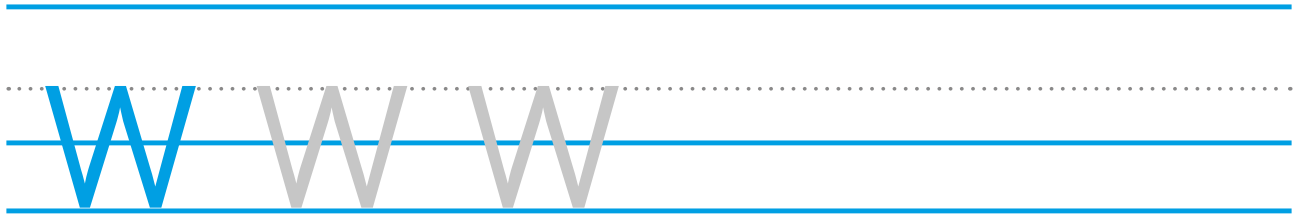

Trace and copy.

Y Y Y

y y y

Z Z Z

z z z

# Handwriting Practice

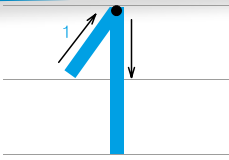

one

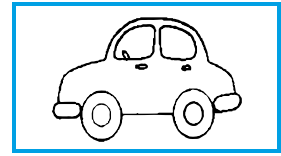

Copy the numbers.

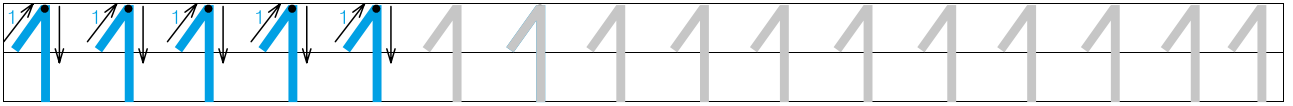

1

Copy the words.

one car

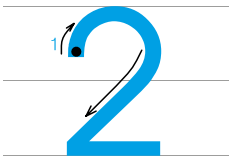

two

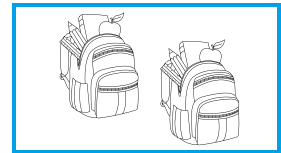

Copy the numbers.

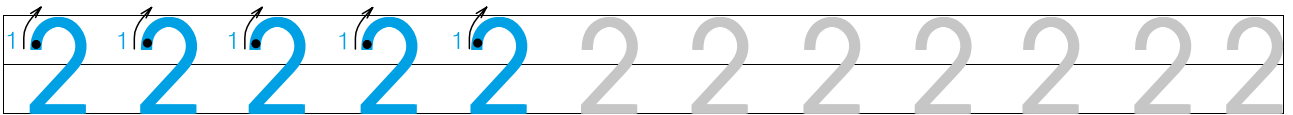

2

Copy the words.

two bags

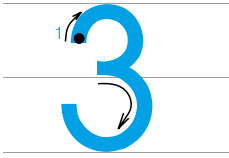

three

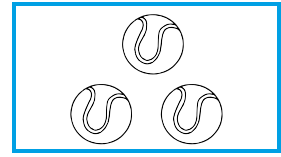

Copy the numbers.

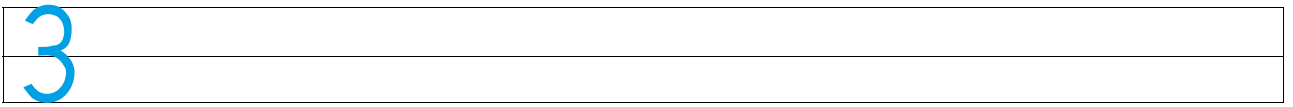
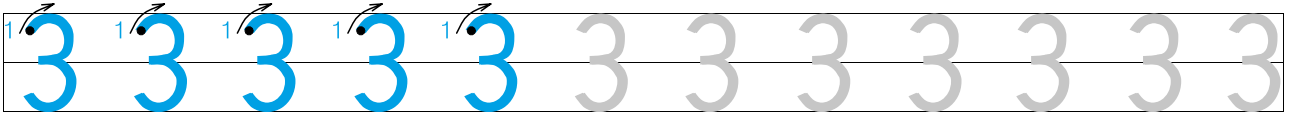

Copy the words.

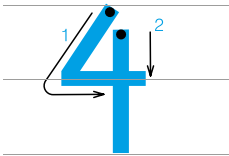
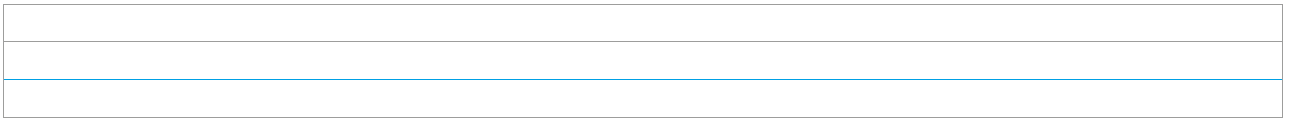
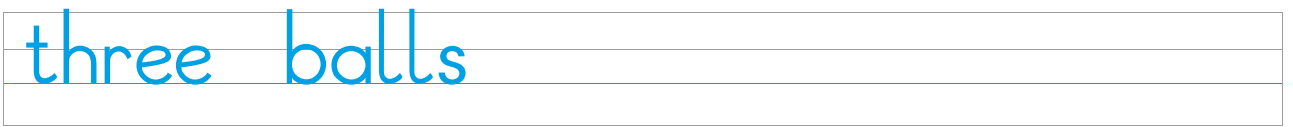

four

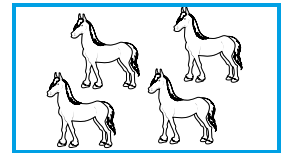

Copy the numbers.

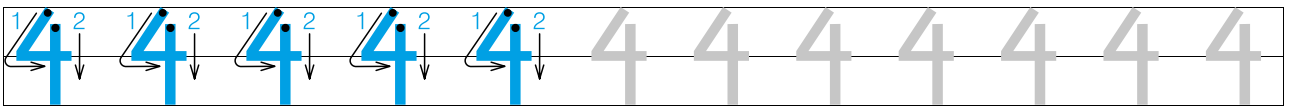

Copy the words.

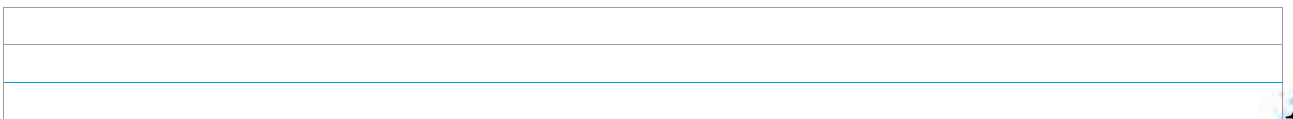
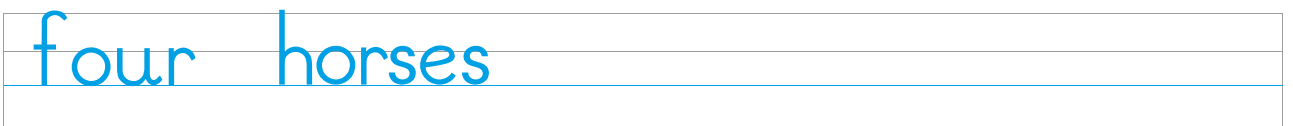

# Handwriting Practice

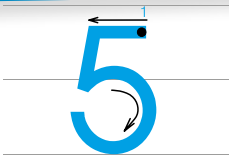

five

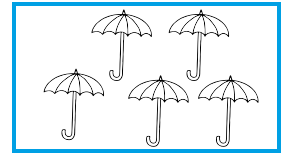

Copy the numbers.

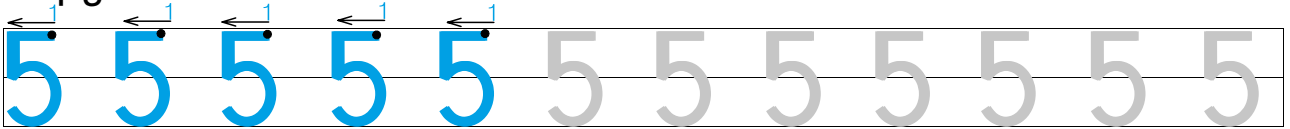

5

Copy the words.

five umbrellas

Blank handwriting lines for copying the words.

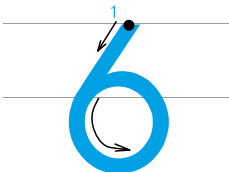

six

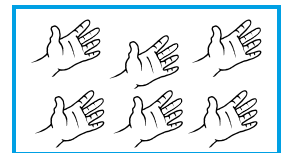

Copy the numbers.

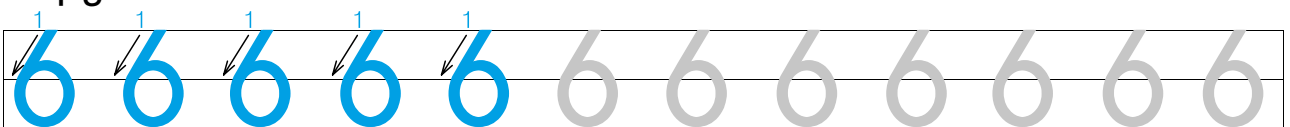

6

Copy the words.

six hands

Blank handwriting lines for copying the words.

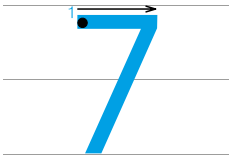

seven

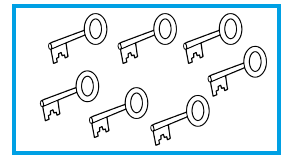

Copy the numbers.

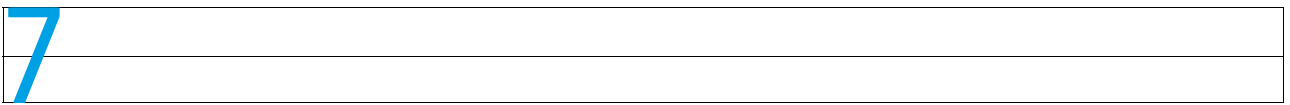
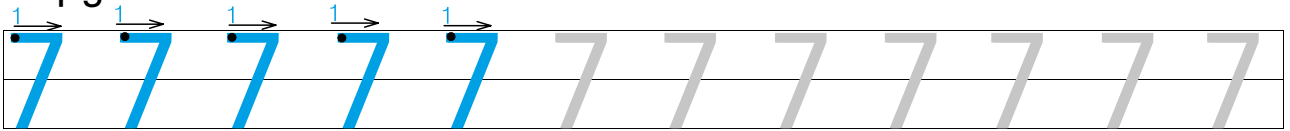

Copy the words.

seven keys

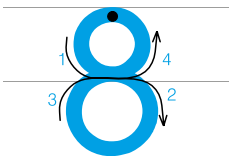
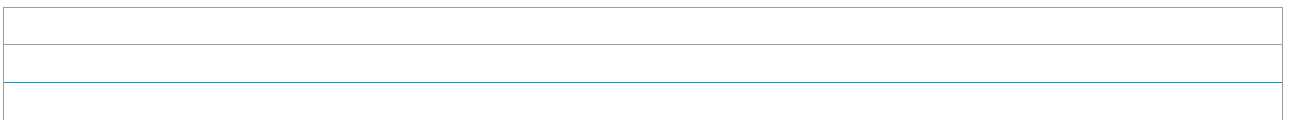

eight

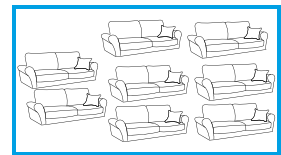

Copy the numbers.

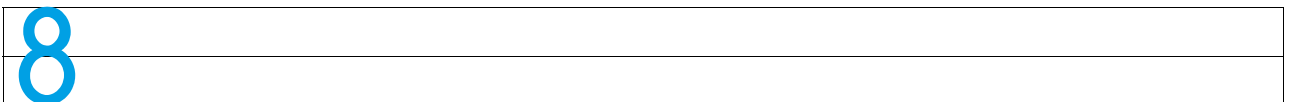
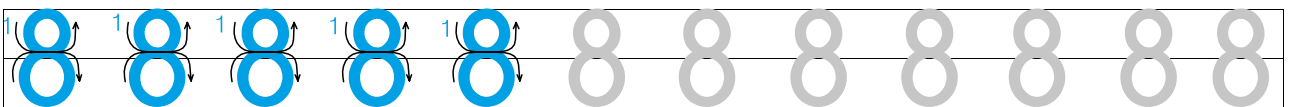

Copy the words.

eight sofas

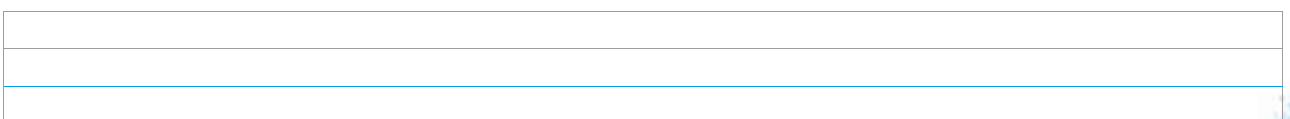

# Handwriting Practice

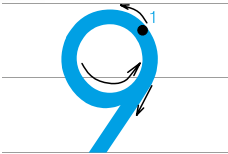

nine

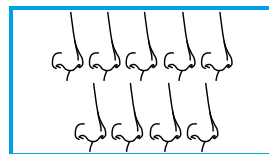

Copy the numbers.

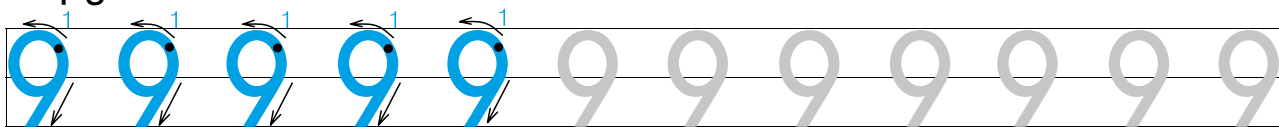

Copy the words.

nine noses

Blank handwriting lines for copying practice.

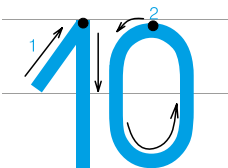

ten

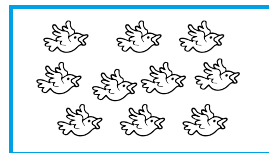

Copy the numbers.

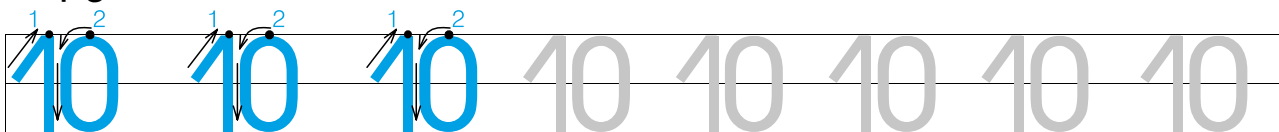

Copy the words.

ten birds

Blank handwriting lines for copying practice.